

Hydraulic Excavators

SK85CS

- Bucket Capacity :
0.29 cu.yd. (0.22 m³) SAE heaped
- Engine Power :
55.0 hp (41kW) / 2,000 rpm (SAE NET)
- Operating Weight :
18,700 lb (8,490 kg)



Note: This catalog may contain attachments and optional equipment that are not available in your area. It may also contain photographs of machines with specifications that differ from those of machines sold in your area. Please consult your nearest KOBELCO distributor for those items you require. Due to our policy of continuous product improvements all designs and specifications are subject to change without advance notice. Copyright by **KOBELCO CONSTRUCTION MACHINERY CO., LTD.** No part of this catalog may be reproduced in any manner without notice.

KOBELCO CONSTRUCTION MACHINERY U.S.A. INC.

4690 World Houston Parkway Houston, TX 77032
<http://www.kobelco-usa.com/>

Inquiries To:

Bulletin No. SK85CS-NA-201

2013080000EF Printed in USA

Complies with the latest exhaust emission regulations



US EPA
Tier IV Final



EU (NRMM)
Stage III B



Japanese
Regulations

**DRIVEN BY
PASSION**

Fuel Consumption Gives You the Competitive Edge

KOBELCO's SR hydraulic excavator has undergone a new evolution.

KOBELCO has installed its full range of fuel-saving technologies in this SR model, resulting in unmatched low fuel consumption that provides a class leading standard of efficiency for engine-driven hydraulic excavators.

Outstanding performance in tight spaces, on-site safety, less stress for the operator. KOBELCO was first to understand these demands and in response developed SR, short rear swing, excavators. The acclaimed SR concept went on to be adopted throughout the industry.

But KOBELCO didn't stop there. Aware of changing needs among machine users in a changing social environment, KOBELCO has taken the SR concept through a further evolution with value-added features.

KOBELCO's unique design for engine cooling, the iNDR system, cuts noise to extremely low levels.

The newest KOBELCO approach to low fuel consumption, NEXT-3E, now also applies to short rear swing models to maximize work volumes while saving on fuel. And the new ECO-mode in the SK85CS creates even greater savings on fuel to turn SR models into exceptional high-earning machines.

KOBELCO continues to lead the field in short rear swing excavators.

Five Ways the SK85CS Scores:

- Low Noise: iNDR
- More Work with Less Fuel!
- Efficient Performance!
- Fast, Accurate and Low-Cost Maintenance
- A Working Environment that Helps Operator Concentrate on the Job



NEXT-3E



Pursuing the "Three E's"
The Perfection of Next-Generation,
Network Performance

Enhancement

Greater Performance Capacity

Economy

Improved Cost Efficiency

Environment

Features That Go Easy on the Earth

The Revolutionary Integrated Noise and Dust Reduction Cooling System

Ultimate Low Noise

KOBELCO's exclusive iNDR Cooling System delivers amazingly quiet operation.

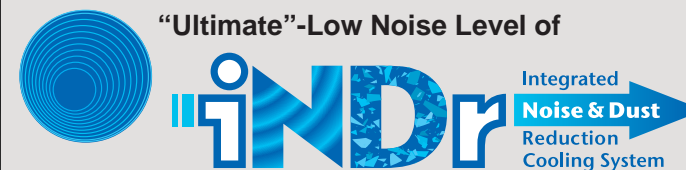

"Ultimate"-Low Noise Level of



The iNDR revolution



● Concept

KOBELCO has developed the revolutionary integrated Noise and Dust Reduction Cooling System, with the engine compartment placed inside a single duct that connects the air intake to the exhaust outlet.



● Reduces Noise

The intake and exhaust are offset, with the holes and joints in the sections corresponding to the duct wall completely covered to reduce noise at the intake and exhaust apertures. This design, coupled with the generous use of insulation-material inside the duct, minimizes engine noise.



● Reduces Dust

The high-performance iNDR filter removes dust from the intake air, ensuring a quieter, cleaner engine and keeps the cooling unit free of clogging so that no regular cleaning is necessary.

More Work with Less Fuel!

Fuel Consumption and Work Volume

The new hydraulic system and an additional ECO-mode have cut fuel consumption by up to 31%.

H-mode (vs previous SK80CS in H-mode)

Fuel consumption (L/h)

5% decrease ↓

Work volume per liter of fuel (m³/L)

11% increase ↑

S-mode (vs previous SK80CS in H-mode)

Fuel consumption (L/h)

11% decrease ↓

Work volume per liter of fuel (m³/L)

16% increase ↑

ECO-mode (vs previous SK80CS in S-mode)

Great leap forward in energy-saving performance

Fuel consumption (L/h)

31% decrease ↓

Work volume per liter of fuel (m³/L)

38% increase ↑

* Figures for fuel consumption: fuel consumed per hour (L/h) compared with previous model, in KOBELCO tests.

* Figures for work volume: digging volume per liter of fuel (m³/L) compared with previous model, in KOBELCO tests.

ECO-mode

Work modes for a closer match to the job at hand. In addition to the existing H-mode and S-mode, the new ECO-mode saves even more energy.



H-mode: For heavy duty operation, when a higher performance level is required.

S-mode: For normal operations with lower fuel consumption.

ECO-mode: Puts priority on low fuel consumption and economic performance.

Significant Extension of Continuous Working Hours

The combination of a large-capacity fuel tank and excellent fuel efficiency delivers an impressive increase in the length of continuous usage.

Fuel tank capacity:
 **31.7 U.S.gal**
(120 L)

NEXT-3E Technology New Hydraulic System

KOBELCO's hydraulic circuit analysis is combined with the use of new, high-efficiency pumps in a three-pump electro-hydraulic actuator control system that replaces the conventional mechanical system. It all adds up to a hydraulic system that delivers maximum efficiency: Class leading work performance on less fuel.

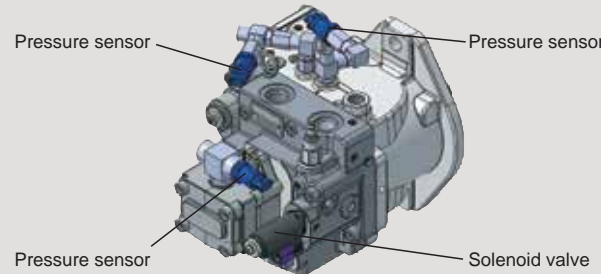

NEXT-3E Technology Total Tuning Through Advanced ITCS Control

The next-generation engine control is governed by a new version of ITCS, which responds quickly to sudden changes in hydraulic load to ensure that the engine runs as efficiently as possible with a minimum of wasted output.

ITCS ITCS (Intelligent Total Control System) is an advanced, computerized system that provides comprehensive control of all machine functions.

NEXT-3E Technology Next-Generation Electronic Engine Control

The new electronic-control common-rail engine features high-pressure fuel injection and multiple injection with improved precision. It is fitted with an EGR cooler, and DOC which deliver high engine output from optimized combustion and greatly reduces PM and NOx emissions.



Tier4 compliant engine

PM emissions cut: Limits creation of particulate matter (which results from incomplete combustion of fuel)

■ Common rail system

High-pressure injection atomizes the fuel, and injection timing is more precise which improves combustion efficiency.

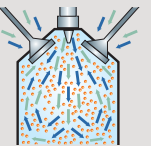

■ DOC (Diesel Oxidation Catalyst)

Carbon builds up as soot on the diesel particulate filter and is burned off at high temperature. No Exhaust fluid is required. The system allows manual or automatic filter regeneration.



NOx emissions cut: Reduces nitrogen oxides (created by reaction with oxygen at high temperature)

■ EGR cooler

While ensuring sufficient oxygen for combustion, cooled exhaust gases are mixed with the air intake and re-circulated into the engine. The lowered oxygen temperature lowers the combustion temperature and increases combustion efficiency.

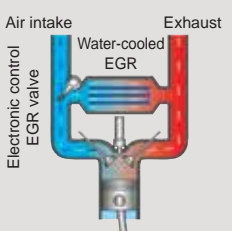

Automatic Acceleration / Deceleration Function Reduces Engine Speed

Engine speed is automatically reduced when the control lever is placed in neutral, effectively saving fuel and reducing noise and exhaust emissions. The engine quickly returns to the previous speed when the lever is moved out of neutral.

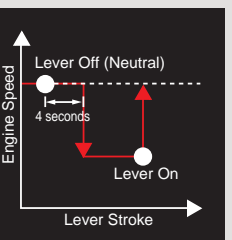

Photos in this catalog are the machine with the option installed.

Efficient Performance!

Top-Class Powerful Digging

For more efficient work performance.
(SAE J1179:1990)

Max. arm crowding force: **7,700 lbs {34.2 kN}**

Max. bucket digging force: **14,658 lbs {65.2 kN}**

Powerful Travel

A new type of travel motor boosts travel torque by 6%, and the lighter machine weight improves steering performance by 10% over the previous model, for better maneuverability and crisper turns.

Travel torque: **6% increase**

Drawbar pulling force: **17,300 lbs {76.8 kN}**



Dozer Simultaneous Operations

With separate pumps for travel motor and dozer there's no hydraulic interference when traveling at top speed. Dozer operation is fast, rugged, and stress-free.

Dozer Raising/Lowering Margin Increased

Dozer can be raised higher and powered more to make work more productive.

500 mm



405 mm

Boom Swing Mechanism

The boom can swing up to 62° to the left and 67° to the right, making it possible to perform side-digging parallel to the crawlers without moving the machine.



Excellent Working Ranges

Working ranges are further extended, with significant increases in maximum working radius and maximum digging depth.

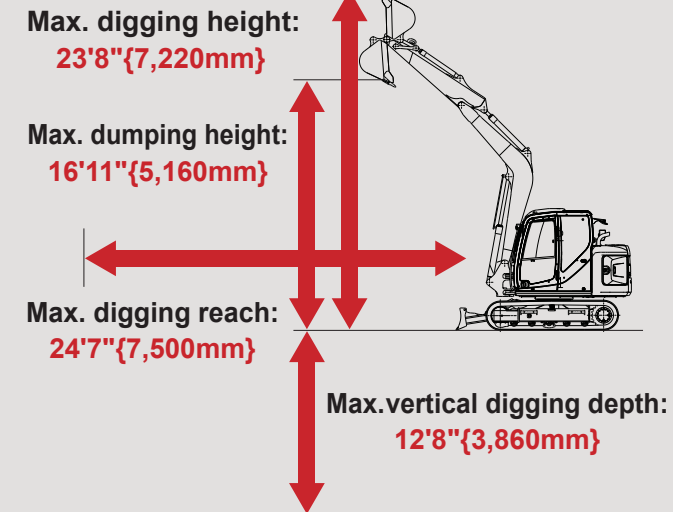

Great Swing Power, Short Cycle Times

Powerful swing power and top-class swing speed.

Swing speed: **11.5 rpm**

Requires 12 ft. 11 in. of Working Space

With a 180° working radius of just 12 feet 11 inches, SK85CS can dig, swing, and load continuously.



Working radius equals the sum of the minimum front swing radius and tail swing radius. When the add-on type counterweight (+400 kg) is installed, the values of tail overhang and tail swing radius are increased.

Mild Operating Sound

The iNDR cooling system also helps to keep the machine quiet, even at close quarters.

Meets EMC(Electromagnetic Compatibility) Standards in Europe

Electrical shielding ensured that the machines clear all European standards and neither cause or are affected by electromagnetic interference.

A Working Environment that Helps the Operator Concentrate on the Job at Hand!

Big Cab



The large cab provides a roomy operating space with plenty of legroom, and the door opens wide for entry and exit. As well as giving a wide, open view to the front, the cab has increased window areas on both sides and to the rear, for improved visibility in all directions.

Excellent Visibility

Eliminating the right-side cab support to make a single window has improved visibility to the right.



Wide-Access Cab Aids Smooth Entry and Exit

Entry and exit is simple with a wider cab entry and safety lock lever integrated with mounting for control levers.

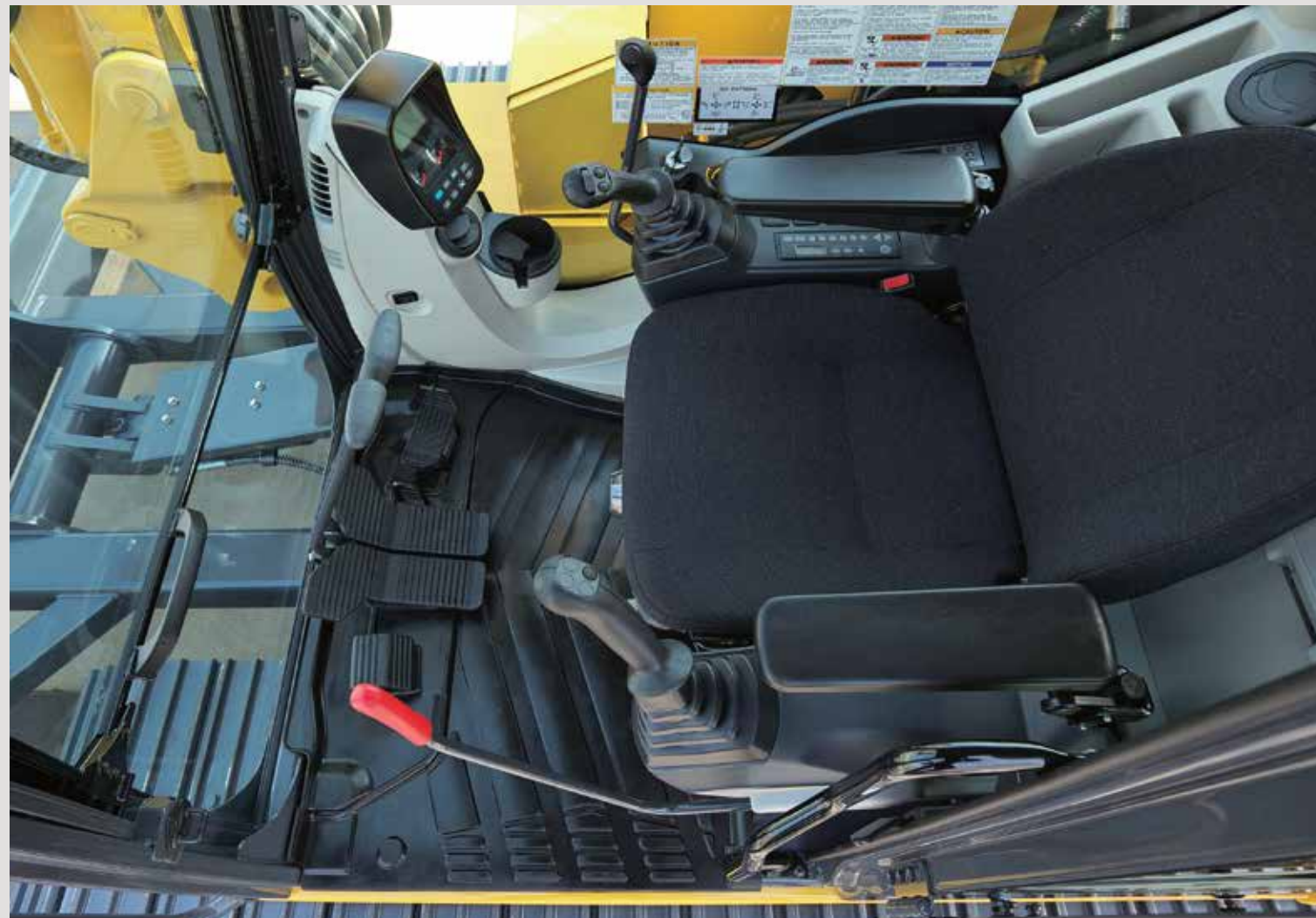

Comfortable Operating Environment



● Double slide seat



● Reclining seat



● Spacious luggage tray



● Large cup holder



● Powerful automatic air conditioner



● Two-speaker FM/AM radio with station select



● One-touch lock release simplifies opening and closing front window



● Travel speed select switch
The travel speed select switch is placed on the dozer lever and it allows selecting the travel speed.

Always Easy to Read! New Information Display



Large gauges with large numbers and letters and glare-reducing visors are always easy to read regardless of working conditions.

ROPS Cab

The newly developed, ROPS (Roll-Over-Protective Structure)-compliant cab clears ISO standards (ISO-12117-2: 2008) and ensures greater safety for the operator.



- Level 2 FOPS Guard (ISO 10262) is equipped as standard.
- To fit vandalism guards, please contact your KOBELCO dealer. (Mounting brackets for vandalism guards)



● FOPS guard (Meets or exceeds current OSHA standards)

Safety Features



● Protective panel separates the pump compartment from the engine



● Retractable seatbelt requires no manual adjustment



● Rear view camera



● Hammer for emergency exit

- Handrails meet European standards
- Thermal guard prevents contact with hot components during engine inspections
- Travel alarm
- Swing flasher



Engine

Model	ISUZU AU-4LE2X
Type:	Direct injection, water-cooled, 4-cycle diesel engine With turbocharger, intercooler
	US EPA Tier IV Final, and act on regulation, etc. of emission from non-road special motor vehicles (Japan))
No. of cylinders:	4
Bore and stroke:	3.35' (85 mm) × 3.78' (96 mm)
Displacement:	133 cu.in. (2.179 L)
Rated power output:	55.0hp {41kW} /2,000rpm (SAE NET)
Max. torque:	148 lb-ft {210N·m} /1,800rpm (SAE NET)



Hydraulic System

Pump	
Type:	Two variable displacement pumps
Max. discharge flow:	2 × 17.5 U.S.gph {2 x 66 L/min} , 1 × 12.2 U.S.gph {1 x 46 L/min}
Relief valve setting	
Boom, arm and bucket:	4,260 psi {29.4 Mpa}
Travel circuit:	4,260 psi {29.4 Mpa}
Dozar blade circuit:	3,200 psi {22.1 Mpa}
Swing circuit:	3,550 psi {24.5 Mpa}
Control circuit:	730 psi {5.0 Mpa}
Pilot control pump:	Gear type
Main control valves:	13-spool
Oil cooler:	Air cooled type



Swing System

Swing motor:	Axial piston motor
Parking brake:	Oil disc brake, hydraulic operated automatically
Swing speed:	11.5 rpm
Swing torque:	12,500 lb-ft {17 kN·m} (SAE)
Tail swing radius:	5'5" {1,650 mm}
Min. front swing radius:	9'1" {2,780 mm}



Attachments

Backhoe bucket and arm combination

Use	Backhoe bucket							
	Normal digging							
Bucket capacity	SAE heaped	cu.yd. {m³}	0.14 {0.11}	0.18 {0.14}	0.23 {0.18}	0.29 {0.22}	0.37 {0.28}	0.46 {0.35}
	Struck	cu.yd. {m³}	0.11 {0.09}	0.16 {0.12}	0.18 {0.14}	0.24 {0.18}	0.27 {0.21}	0.34 {0.26}
Opening width	With side cutter	inches {mm}	-	19 {480}	22 {550}	26 {650}	30 {750}	33 {850}
	Without side cutter	inches {mm}	16 {400}	16 {410}	19 {480}	23 {580}	27 {680}	31 {780}
No. of bucket teeth			3	3	3	4	4	4
Bucket weight		lbs {kg}	330 {150}	350 {160}	370 {170}	420 {190}	460 {210}	460 {210}
Combinations	5'7" {1.71 m} arm		○	○	○	○	◎	△
	7'0" {2.13 m} arm		○	○	○	◎	△	—

◎ Standard ○ Recommended △ Loading only



Travel System

Travel motors:	2 x axial piston, two-speed motors
Parking brakes:	Oil disc brake per motor
Travel shoes:	39 each side
Travel speed:	3.3 / 1.6 mph {5.3 / 2.6 km/h}
Drawbar pulling force:	17,300 lbs {76.8 kN} (SAE J 1309)
Gradeability:	70 % {35°}



Cab & Control

Cab	
All-weather, sound-suppressed steel cab mounted on the silicon-sealed viscous mounts and equipped with a heavy, insulated floor mat.	
Control	
Two hand levers and two foot pedals for travel	
Two hand levers for excavating and swing	
Electric rotary-type engine throttle	



Boom, Arm & Bucket

Boom cylinder:	4.33" {110 mm} × 3'0" {916 mm}
Arm cylinder:	3.74" {95 mm} × 2'8" {833 mm}
Bucket cylinder:	3.15" {80 mm} × 2'5" {735 mm}



Boom Swing Mechanism

Control:	Foot pedal
Boom swing angle:	62° to the left, 67° to the right
Swing cylinder:	4.13" {105mm} × 1'11" {586mm}



Dozer Blade

Dozer cylinder:	5.71" {145 mm} × 6.50" {165 mm}
Dimension:	8'0" {2,450 mm} × 1'6" {455 mm}
Working range:	1'2" {500 mm} × 1'4" {405 mm}



Refilling Capacities & Lubrications

Fuel tank:	31.7 U.S.gal {120 L}
Cooling system:	2.25 U.S.gal {8.5 L}
Engine oil:	2.9 U.S.gal {11 L}
Travel reduction gear:	2 × 0.36 U.S.gal {2 × 1.35 L}
Swing reduction gear:	0.4 U.S.gal {1.5 L}
Hydraulic oil tank:	9.5 U.S.gal {36 L} tank oil level 22.5 U.S.gal {85 L} hydraulic system



Working Ranges

Unit: ft-in {m}

Range	Arm	12'1" {3.67 m}	
		6'2" {1.87m}	7'0" {2.13 m}
a- Max. digging reach		23'9" {7.24}	24'7" {7.5}
b- Max. digging reach at ground level		23'2" {7.07}	24'1" {7.34}
c- Max. digging depth		13'9" {4.2}	14'8" {4.46}
d- Max. digging height		23'0" {7.0}	23'8" {7.22}
e- Max. dumping clearance		16'2" {4.94}	16'11" {5.16}
f- Min. dumping clearance		6'4" {1.93}	5'6" {1.68}
g- Max. vertical wall digging depth		11'6" {3.5}	12'8" {3.86}
h- Min. swing radius		8'10" {2.7}	9'1" {2.78}
i- Horizontal digging stroke at ground level		10'2" {3.11}	11'6" {3.51}
j- Digging depth for 8 feet flat bottom		12'7" {3.84}	13'7" {4.14}
Bucket capacity SAE heaped cu.yd. {m³}		0.37 {0.28}	0.29 {0.22}

Digging Force

Unit: lbs {kN}

Arm length		6'2" {1.87m}	7'0" {2.13m}
		Bucket digging force	SAE 14,658 {65.2}
	ISO	16,456 {73.2}	16,456 {73.2}
Arm crowding force	SAE	8,100 {35.9}	7,700 {34.2}
	ISO	8,300 {37.1}	7,900 {35.2}



Dimensions

Arm length	Short 6'2" {1.87m} ARM	Standard 7'0" {2.13m} ARM
A Overall length	22'1" {6,740}	22'2" {6,760}
B Overall height (to top of boom)	7'11" {2,410}	8'5" {2,560}
C Overall width of crawler	8'0" {2,450}	
D Overall height (to top of cab)	8'6" {2,600}	
E Ground clearance of rear end*	27.6" {700}	
F Ground clearance*	13.8" {350}	

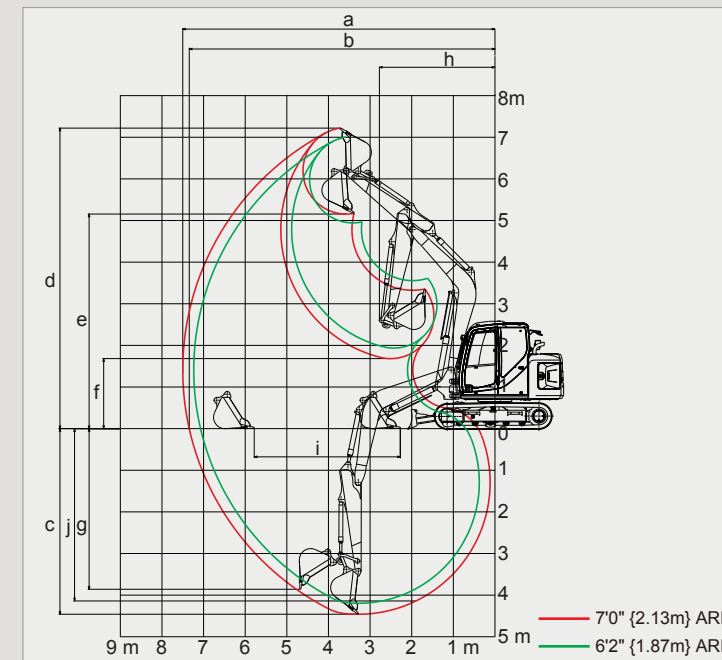

	Unit: ft-in {mm}
G Tail swing radius	5'5" {1,650} (5'10" {1,780}**)
H Tumbler distance	7'3" {2,210}
I Overall length of crawler	9'3" {2,830}
J Track gauge	6'1" {1,850}
K Shoe width	23.6" {600}
L Overall width of upperstructure	7'5" {2,250}
M Dozer blade (up/down)	20" {500} / 16" {405}

* Without including height of shoe lug
** With add-on type counterweight (+400kg)

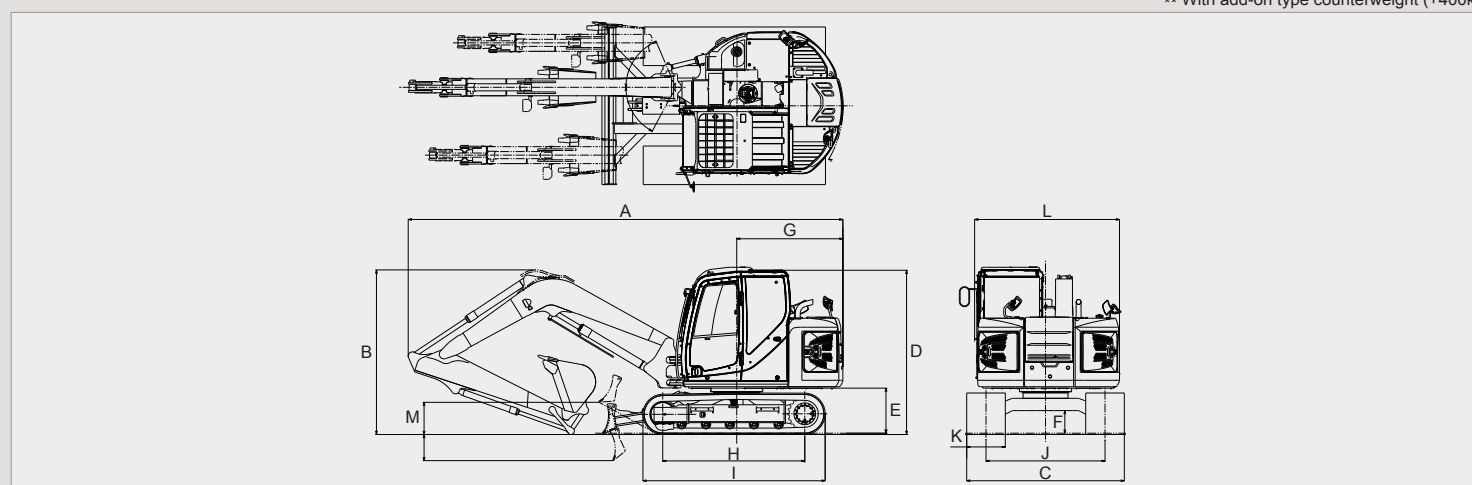

Operating Weight & Ground Pressure

In standard trim, with standard boom, 7'0" {2.13m} arm, and 0.29 cu.yd. {0.22m³} SAE heaped bucket

Shaped	Triple grouser shoes (even height)	
Shoe width	ft-in {mm}	23.6" {600}
Overall width of crawler	ft-in {mm}	8'0" {2,450}
Ground pressure	psi {kPa}	4.2 {28.6}
Operating weight	lbs {kg}	18,700 {8,490}

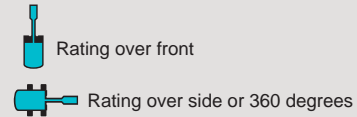
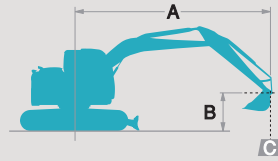

A – Reach from swing centerline for bucket hook
B – Bucket hook height above/below ground
C – Lifting capacities in pounds

SK85MSR-3E		Arm: 6'2" {1.87m} Bucket: 0.37cu.yd. {0.28m ³ } SAE heaped 460 lbs {210kg} Counterweight : 1,760 lbs {800kg} Shoe: 23.6" {600mm} Dozer : blade down										
		5' {1.5m}		10' {3.0m}		15' {4.6m}		20' {6.1m}		At Max. Reach		Radius
B	A											
15' {4.6m}	lb{kg}					*3,770{1,710}	3,370{1,520}			*2,330{1,050}	*2,330{1,050}	17'1" {5.21m}
10' {3.0m}	lb{kg}					*4,380{1,980}	3,220{1,460}			*2,340{1,060}	1,970{890}	19'8" {6.00m}
5' {1.5m}	lb{kg}			*10,340{4,690}	5,420{2,450}	*5,590{2,530}	2,930{1,320}	*3,700{1,670}	1,820{820}	*2,640{1,190}	1,740{780}	20'6" {6.26m}
G.L.	lb{kg}			*10,140{4,590}	5,000{2,260}	*6,350{2,880}	2,710{1,220}			*3,410{1,540}	1,760{790}	19'10" {6.06m}
-5' {-1.5m}	lb{kg}	*8,280{3,750}	*8,280{3,750}	*10,080{4,570}	5,010{2,270}	*5,890{2,670}	2,660{1,200}			*4,570{2,070}	2,110{950}	17'6" {5.35m}
-10' {-3.0m}	lb{kg}			*5,850{2,650}	5,250{2,380}					*4,520{2,050}	3,820{1,730}	12'2" {3.72m}

SK85MSR-3E		Arm: 7'0" {2.13m} Bucket: 0.29cu.yd. {0.22m ³ } SAE heaped 420 lbs {190kg} Counterweight : 1,760 lbs {800kg} Shoe: 23.6" {600mm} Dozer : blade down										
		5' {1.5m}		10' {3.0m}		15' {4.6m}		20' {6.1m}		At Max. Reach		Radius
B	A											
15' {4.6m}	lb{kg}					*3,470{1,570}	*3,470{1,570}			*1,970{890}	*1,970{890}	18'2" {5.55m}
10' {3.0m}	lb{kg}					*4,130{1,870}	3,330{1,510}	*2,750{1,240}	2,000{900}	*1,950{880}	1,880{850}	20'8" {6.30m}
5' {1.5m}	lb{kg}			*9,730{4,410}	5,660{2,560}	*5,440{2,460}	3,040{1,370}	*4,110{1,860}	1,900{860}	*2,160{970}	1,680{760}	21'5" {6.54m}
G.L.	lb{kg}	*3,980{1,800}	*3,980{1,800}	*10,110{4,580}	5,140{2,330}	*6,370{2,880}	2,800{1,270}	*4,350{1,970}	1,800{810}	*2,680{1,210}	1,690{760}	20'10" {6.35m}
-5' {-1.5m}	lb{kg}	*7,280{3,300}	*7,280{3,300}	*10,690{4,840}	5,090{2,300}	*6,160{2,790}	2,720{1,230}			*4,090{1,850}	1,980{890}	18'7" {5.68m}
-10' {-3.0m}	lb{kg}			*7,030{3,180}	5,270{2,390}					*4,450{2,010}	3,170{1,430}	13'10" {4.23m}

Notes:

- Do not attempt to lift or hold any load that is greater than these lift capacities at their specified lift point radius and heights. Weight of all accessories must be deducted from the above lift capacities.
- Lift capacities are based on machine standing on level, firm, and uniform ground. User must make allowance for job conditions such as soft or uneven ground, out of level conditions, side loads, sudden stopping of loads, hazardous conditions, experience of personnel, etc.
- Bucket lift hook is defined as lift point.
- The above rated loads are in compliance with SAE Hydraulic Excavator Lift Capacity Rating Standard J 1097. They do not exceed 87% of hydraulic lifting capacity or 75% of tipping load. Rated loads marked with asterisk (*) are limited by hydraulic capacity rather than tipping load.
- Operator should be fully acquainted with the Operator's and Maintenance Instructions before operating this machine. Rules for safe operation of equipment should be adhered to at all times.
- Lift capacities apply to only machines as originally manufactured and normally equipped by KOBELCO CONSTRUCTION MACHINERY CO., LTD.

STANDARD EQUIPMENT

ENGINE

- Engine, ISUZU AU-4LE2X engine with turbocharger and intercooler, Tier 4 Final certified
- Automatic engine deceleration
- Batteries (2 x12V - 64 Ah)
- Starting motor (24V - 3.2 kW), 50 A alternator
- Automatic engine shut-down for low engine oil pressure
- Double element air cleaner

CONTROL

- Working mode selector (H-mode, S-mode and ECO-mode)

SWING SYSTEM & TRAVEL SYSTEM

- Swing rebound prevention system
- Two-speed travel with automatic down shift
- Sealed & lubricated track links
- 23.6" {600mm} track shoes
- Grease-type track adjusters
- Automatic swing brake
- Dozer blade

MIRRORS & LIGHTS

- Four rear view mirrors
- Two front working lights (boom, guard)
- Swing flasher

CAB & CONTROL

- ROPS cab
- Two control levers, pilot-operated
- Horn, electric
- Integrated left-right slide-type control box
- Ashtray
- Cab light (interior)
- Coat hook
- Large cup holder
- Detachable two-piece floor mat
- 7-way adjustable suspension seat
- Retractable seatbelt
- Headrest
- Arm rest
- Handrails
- Heater and defroster
- Intermittent windshield wiper with double-spray washer
- Skylight
- Top guard
- Tinted safety glass
- Pull-type front window and removable lower front window
- Easy-to-read multi-display monitor
- Automatic air conditioner
- Emergency escape hammer
- Radio, AM/FM Stereo with speaker
- Travel alarm
- 12V converter
- N&B piping, N&B selector

OPTIONAL EQUIPMENT

- Boom & arm load (lock) holding valve
- Front-guard protective structure (may interfere with bucket action)
- Additional hydraulic circuit
- Additional counterweight (+300 kg)
- Add-on type counterweight (+400 kg)

- Cab additional light
- Additional center track guide
- Rain visor (may interfere with bucket action)
- Belly pan guard
- Control pattern changer (2 way)