

CHIPPING HAMMER

CP 4132

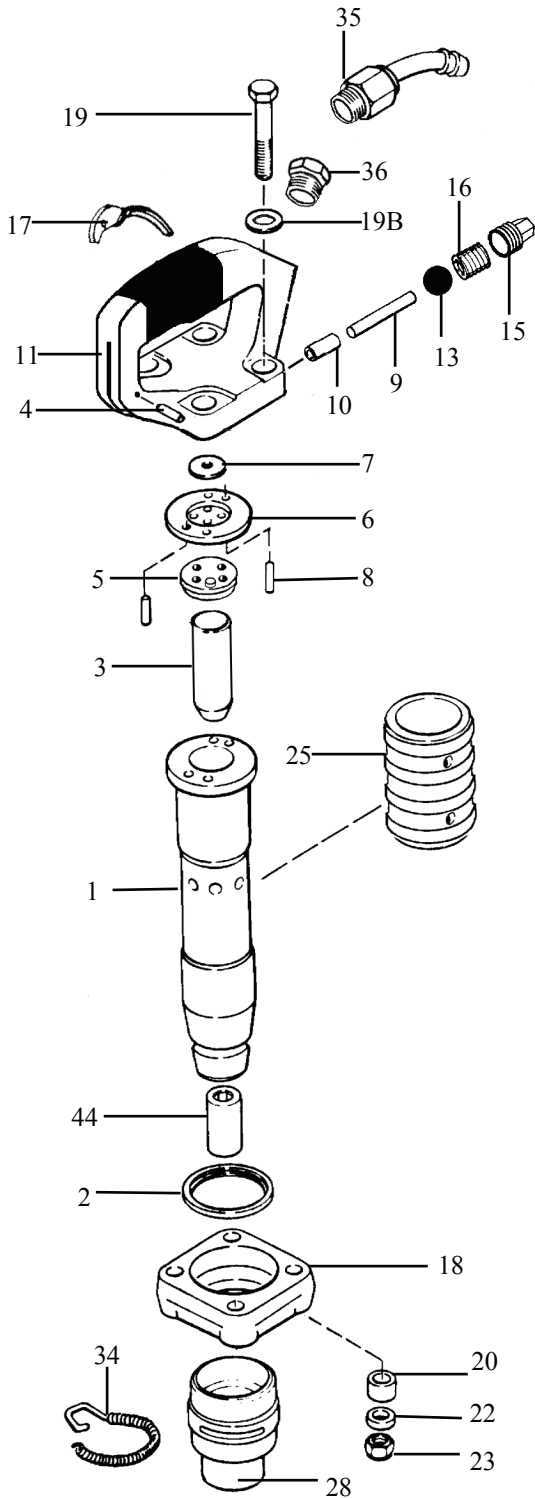

INDEX	PART	DESCRIPTION
1	9245-9983-61	BARREL 3"
2	9245-9963-10	LOCK RING BUMPER
3	9245-9963-30	PISTON 3"
4	9245-9983-64	FULCRUM PIN
5	9245-9963-60	BUMPER VALVE SEAT
6	9245-9983-65	VALVE SPACER
7	9245-9963-50	VALVE PLATE
8	9245-9964-20	VALVE DOWEL (2)
9	9245-9983-67	PUSH PIN
10	9245-9967-00	PUSH PIN BUSHING
11	9245-9983-68	HANDLE BARE
NS	9245-9983-69	HANDLE COMPLETE
13	9245-9964-80	THROTTLE VALVE BALL
15	9245-9965-40	THROTTLE VALVE PLUG
16	9245-9965-30	THROTTLE VALVE SPRING
17	9245-9987-14	TRIGGER
18	9245-9983-70	FLANGE
19	9245-9983-71	HANDLE BOLT (4)
19B	9245-9983-72	SPRING WASHER (4)
20	9245-9983-73	BUMPER WASHER (4)
22	9245-9983-74	HANDLE BOLT SPACER (4)
23	9245-9983-75	HANDLE BOLT NUT (4)
25	9245-9964-40	EXHAUST DEFLECTOR
28	9247-9853-50	OVAL COLLAR RETAINER
34	9245-9964-90	RETAINER SPRING
35	9245-9965-00	SWIVEL(7/8 - 24, 1/2" HOSE BARB)
36	9245-9965-20	HANDLE BUSHING
44	9245-9965-80	BUSHING FOR ROUND SHANK (.680")
44	9245-9965-90	BUSHING FOR HEX SHANK (.580")