

AVAILABLE FOR RENT OR SALE



# MV58



[www.atsequipment.com](http://www.atsequipment.com)

## FORWARD SOIL PLATES

- Cast Iron Plate with tapered edges and ends
- Integrated roll cage and lifting point
- Double sealed non-contact bearings reduces wear
- High centrifugal force

### SPECIFICATIONS

Width x Length	14"x 20"
Manufacture/Model	Honda GX 100, 4-stroke, manual start
Power	3.0 hp
Vibration frequency	5,700 rpm
Amplitude	0.04 in
Centrifugal force	2,338 lbf
Operating speed	82 ft/min
Max tilt	30°
Operating weight	124.3 lbs

### DIMENSIONS

\*Contact area sq feet

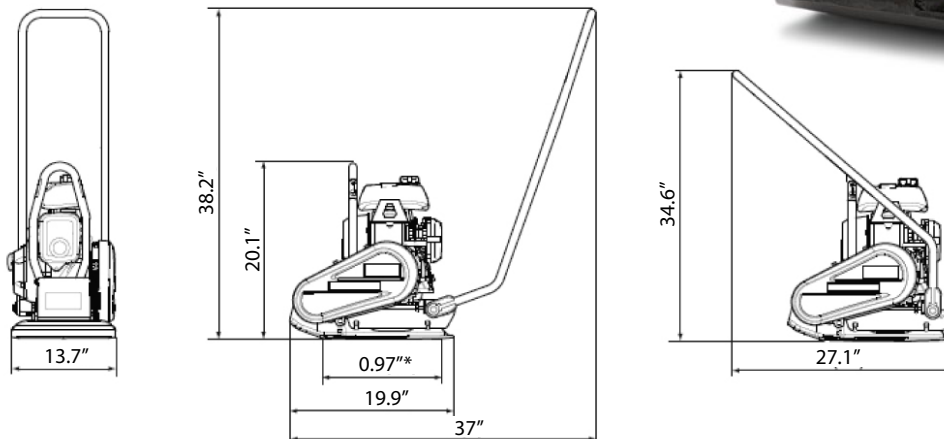

**ATS EQUIPMENT INC. Construction Equipment & Supplies Rentals • Sales • Service**

**BOSTON, MA**  
**(617) 825-3600**

**AUBURN, MA**  
**(508) 832-8500**

**REHOBOTH, MA**  
**(508) 379-6200**

**CANDIA, NH**  
**(603) 483-2100**