

# PARTS MANUAL



*Mikasa* **SERIES**  
**MODEL MVC40H**  
**PLATE COMPACTOR**  
**(HONDA GX100UTVMA GASOLINE ENGINE)**

Revision #1 (06/08/20)

To find the latest revision of this publication or associated operation manual, visit our website at: [www.multiquip.com](http://www.multiquip.com)



**THIS MANUAL MUST ACCOMPANY THE EQUIPMENT AT ALL TIMES.**

# TABLE OF CONTENTS

## MVC40H Plate Compactor

Explanation Of Code In Remarks Column.....	4
Suggested Spare Parts .....	5

## Compactor Component Drawings

Nameplates And Decals .....	6-7
Base And Handle Assembly .....	8-9
Vibrating Plate And Vibrator Assembly.....	10-11
Engine Assembly .....	12-13

## Honda GX100UTVMA Engine

Cylinder Barrel Assembly .....	14-15
Crankcase Cover Assembly.....	16-17
Crankshaft Assembly.....	18-19
Piston And Connecting Rod Assembly.....	20-21
Camshaft Pulley Assembly .....	22-23
Recoil Starter Assembly .....	24-25
Fan Cover Assembly.....	26-27
Carburetor Assembly .....	28-29
Air Cleaner Assembly .....	30-31
Muffler Assembly .....	32-33
Fuel Tank Assembly.....	34-35
Flywheel/Ign. Coil Assembly.....	36-37
Control Assembly .....	38-39

### NOTICE

Specifications and part numbers are subject to change without notice.



# EXPLANATION OF CODE IN REMARKS COLUMN

The following section explains the different symbols and remarks used in the Parts section of this manual. Use the help numbers found on the back page of the manual if there are any questions.

## NOTICE

The contents and part numbers listed in the parts section are subject to change **without notice**. Multiquip does not guarantee the availability of the parts listed.

## SAMPLE PARTS LIST

NO.	PART NO.	PART NAME	QTY.	REMARKS
1	12345	BOLT .....	1	INCLUDES ITEMS W/%
2%		WASHER, 1/4 IN. ....		NOT SOLD SEPARATELY
2%	12347	WASHER, 3/8 IN. ...	1	MQ-45T ONLY
3	12348	HOSE .....	A/R	MAKE LOCALLY
4	12349	BEARING .....	1	S/N 2345B AND ABOVE

## NO. Column

**Unique Symbols** — All items with same unique symbol (@, #, +, %, or >) in the number column belong to the same assembly or kit, which is indicated by a note in the “Remarks” column.

**Duplicate Item Numbers** — Duplicate numbers indicate multiple part numbers, which are in effect for the same general item, such as different size saw blade guards in use or a part that has been updated on newer versions of the same machine.

## NOTICE

When ordering a part that has more than one item number listed, check the remarks column for help in determining the proper part to order.

## PART NO. Column

**Numbers Used** — Part numbers can be indicated by a number, a blank entry, or TBD.

TBD (To Be Determined) is generally used to show a part that has not been assigned a formal part number at the time of publication.

A blank entry generally indicates that the item is not sold separately or is not sold by Multiquip. Other entries will be clarified in the “Remarks” Column.

## QTY. Column

**Numbers Used** — Item quantity can be indicated by a number, a blank entry, or A/R.

A/R (As Required) is generally used for hoses or other parts that are sold in bulk and cut to length.

A blank entry generally indicates that the item is not sold separately. Other entries will be clarified in the “Remarks” Column.

## REMARKS Column

Some of the most common notes found in the “Remarks” Column are listed below. Other additional notes needed to describe the item can also be shown.

**Assembly/Kit** — All items on the parts list with the same unique symbol will be included when this item is purchased.

Indicated by:

“INCLUDES ITEMS W/(unique symbol)”

**Serial Number Break** — Used to list an effective serial number range where a particular part is used.

Indicated by:

“S/N XXXXX AND BELOW”

“S/N XXXX AND ABOVE”

“S/N XXXX TO S/N XXX”

**Specific Model Number Use** — Indicates that the part is used only with the specific model number or model number variant listed. It can also be used to show a part is NOT used on a specific model or model number variant.

Indicated by:

“XXXXX ONLY”

“NOT USED ON XXXX”

**“Make/Obtain Locally”** — Indicates that the part can be purchased at any hardware shop or made out of available items. Examples include battery cables, shims, and certain washers and nuts.

**“Not Sold Separately”** — Indicates that an item cannot be purchased as a separate item and is either part of an assembly/kit that can be purchased, or is not available for sale through Multiquip.

## SUGGESTED SPARE PARTS

### MVC40H PLATE COMPACTOR

1 to 5 units

Qty.	P/N	Description
3	.....070100282.....	V-BELT, RPF-3280
4	.....939010250.....	SHOCK ABSORBER

### HONDA GX100UTVMA ENGINE

1 to 5 units

Qty.	P/N	Description
3	.....9805655777.....	SPARK PLUG
1	.....28462Z0DV03.....	ROPE, RECOIL STARTER
3	.....17211ZL8023 .....	ELE, AIR CLEANER, PAPER
3	.....17218Z0D000.....	ELE, AIR CLEANER, FOAM
1	.....17620Z0J800.....	CAP, FUEL TANK
1	.....16952ZE6000 .....	FUEL STRAINER, FUEL TANK

#### NOTICE

Part numbers on this Suggested Spare Parts list may supersede/replace the part numbers shown in the following parts lists.

# NAMEPLATES AND DECALS

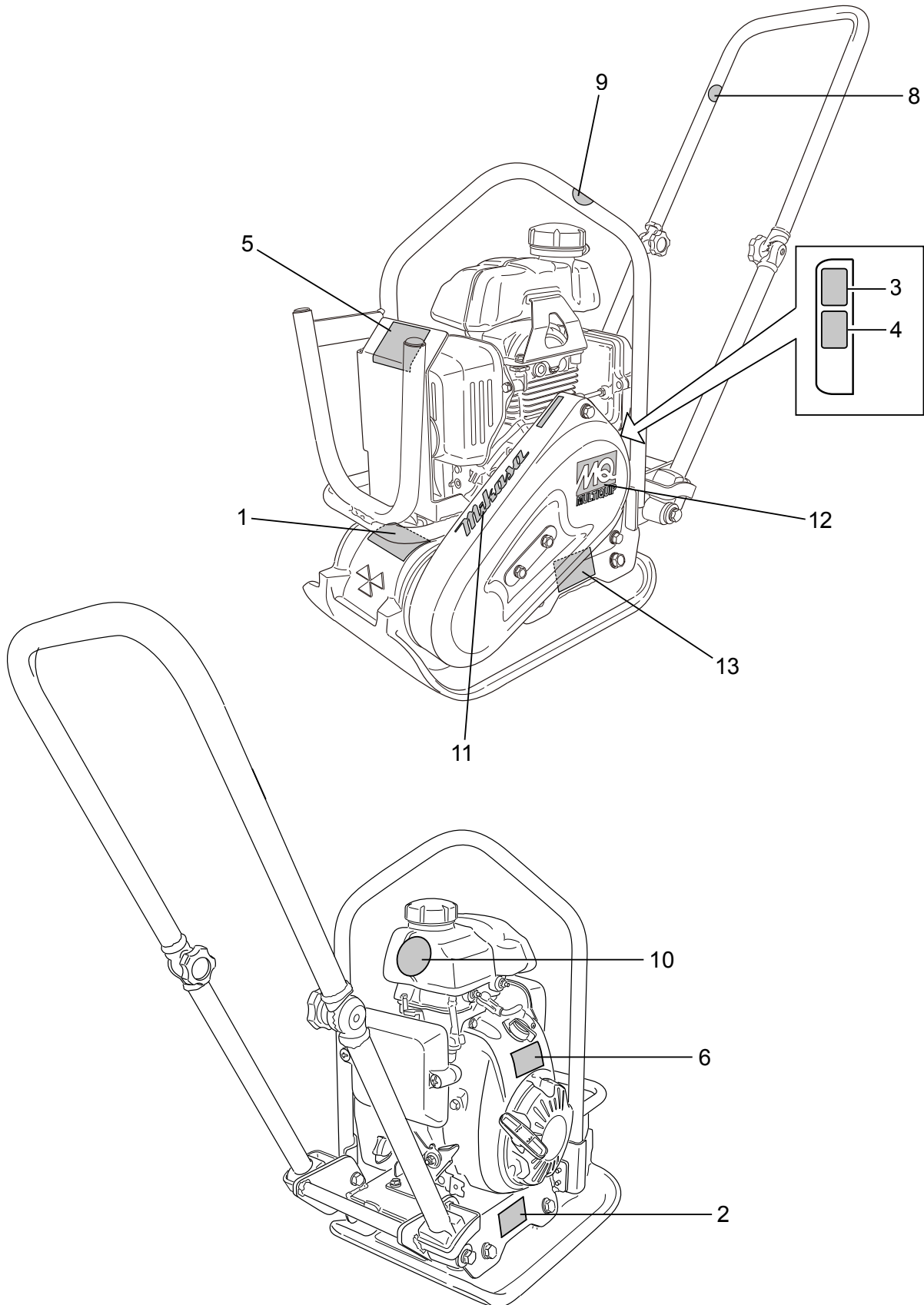

## NAMEPLATES AND DECALS

<u>NO.</u>	<u>PART NO.</u>	<u>PART NAME</u>	<u>QTY.</u>	<u>REMARKS</u>
1	920218740T2	DECAL, CAUTION	1	
2	920218750T2	DECAL, CAUTION	1	
3	920218730T2	DECAL, CAUTION (MANUAL/EXP)	1	
4	920219450T2	DECAL, DANGER	1	
5	920218760T2	DECAL, FUEL CAUTION/MVC	1	
6	920218770	DECAL, E/G FIRE WARNING	1	
7	920221230	DECAL, V-BELT/RPF-3280	1	
8	920900090	DECAL, DO NOT LIFT .....	1.....	REPLACES P/N 920214730
9	920900090	DECAL, LIFTING POSITION .....	1.....	REPLACES P/N 920214740
10	920203330	EAR PROTECTION LABEL	1	
11	920109530	DECAL, MIKASA (125MM) YELLOW	1	
12	920220220	DECAL, MQ MARK 72X57	1	
13	920221790	PLATE, MODEL/SERIAL NUMBER.....	1.....	CONTACT PARTS DEPT.

# BASE AND HANDLE ASSY.

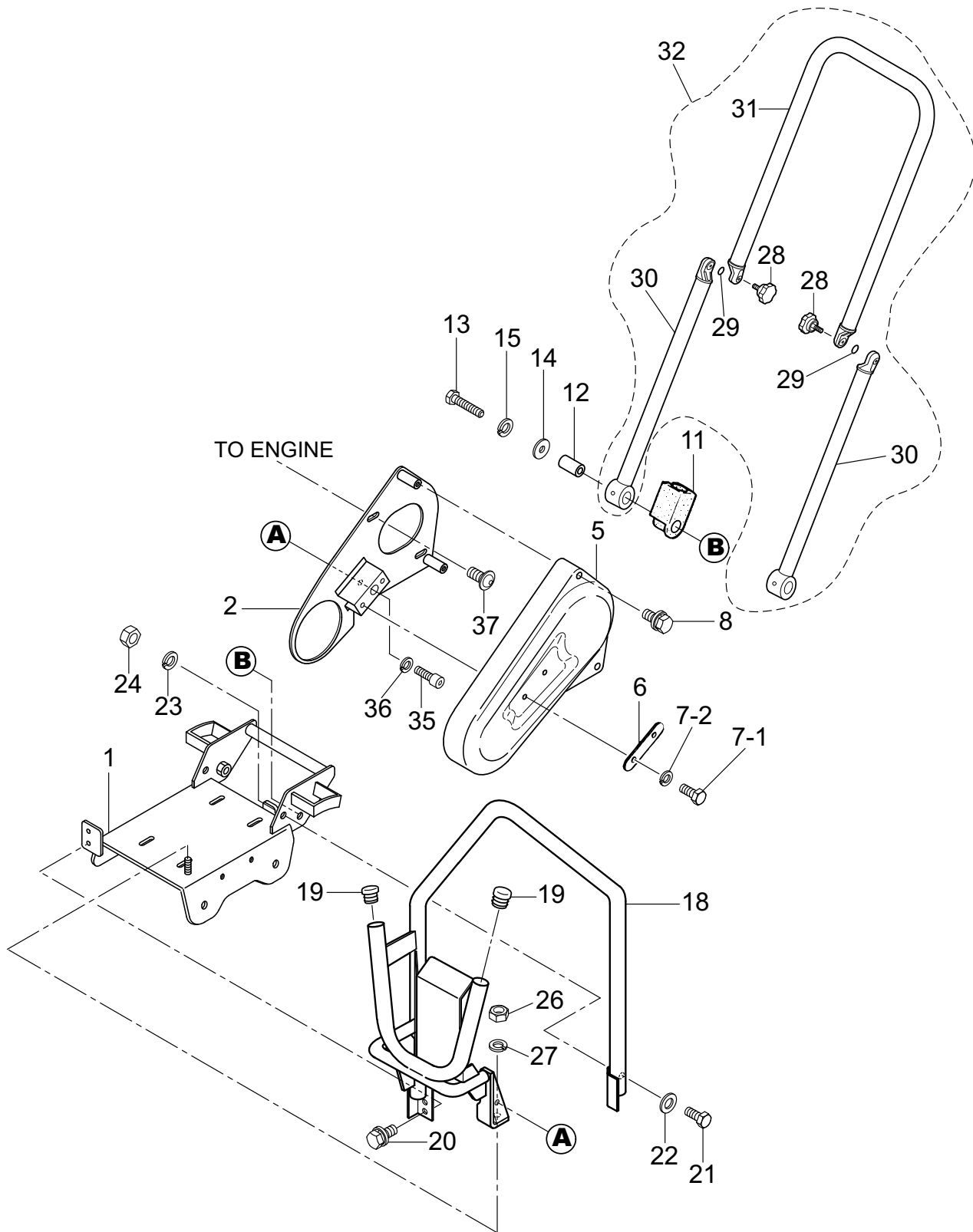



## BASE AND HANDLE ASSY.

<u>NO.</u>	<u>PART NO.</u>	<u>PART NAME</u>	<u>QTY.</u>	<u>REMARKS</u>
1	417122340	BASE	1	
2	417122360	BELT COVER (INNER)	1	
5	417122350	BELT COVER (OUTER)	1	
6	417466230	PLATE, BELT COVER	1	
7-1	014208020	BOLT 8X20.....	2	REPLACES P/N 001220820
7-2	030208200	WASHER, LOCK M8	2	
8	011808015	BOLT, 8X15 HEX HEAD ASSY.....	2	REPLACES P/N 002410815
11	417454410	HANDLE STOPPER	2	
12	417454420	COLLAR	2	
13	012210060	BOLT 10X60.....	2	REPLACES P/N 001221052
14	952401660	WASHER	2	
15	030210250	WASHER, LOCK M10	2	
18	417122380	GUARD HOOK	1	
19	959408080	CAP, PIPE	2	
20	002410820	BOLT, 8X20 HEX HEAD ASSY.	2	
21	0105091025	BOLT 10X25.....	1	REPLACES P/N 001221025
22	031110160	WASHER, FLAT M10	1	
23	030210250	WASHER, LOCK M10	1	
24	020310080	NUT M10	1	
26	020108060	NUT M8.....	1	REPLACES P/N 020308060
27	030208200	WASHER, LOCK M8	1	
28#	959406961	GRIP BOLT 45X10X30	2	
29#	050200080	O-RING	2	
30#	417352430	HANDLE (LOWER)	2	
31#	417355580	HANDLE (UPPER)	1	
32	417910150	FOLDING HANDLE COMPLETE .....	1	INCLUDES ITEMS W/#
35	096208010	SOCKET HEAD BOLT 8X12.....	1	REPLACES P/N 001520812
36	030208200	WASHER, LOCK M8	1	
37	009110102	SOCKET HEAD SCREW 8X16	2	

# VIBRATING PLATE AND VIBRATOR ASSY.

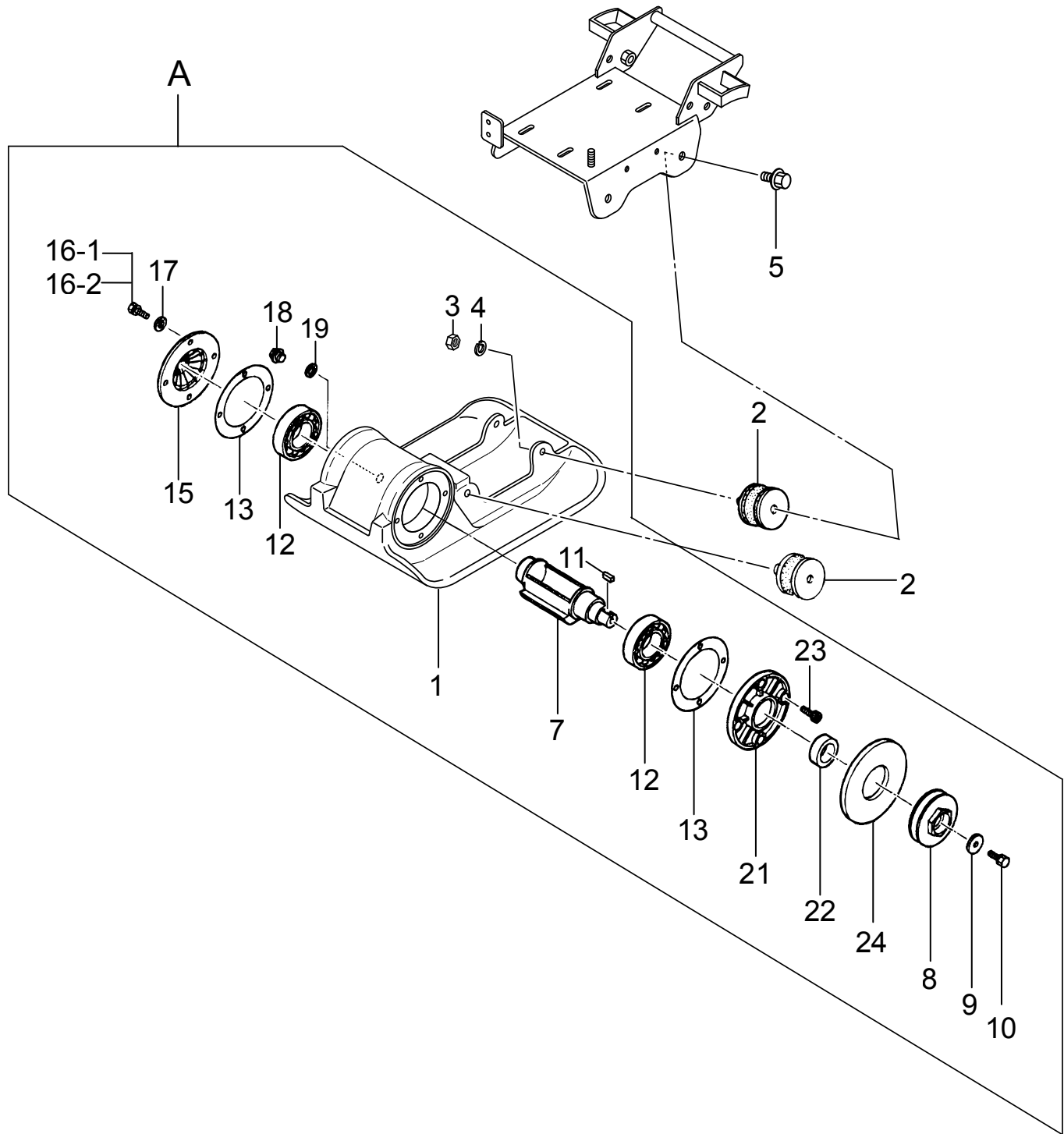

## VIBRATING PLATE AND VIBRATOR ASSY.

<u>NO.</u>	<u>PART NO.</u>	<u>PART NAME</u>	<u>QTY.</u>	<u>REMARKS</u>
A	417910210	VIBRATING PLATE ASSY., COMPLETE .....	1.....	INCLUDES ITEMS W/#
1#	417122310	VIBRATING PLATE	1	
2	939010420	SHOCK ABSORBER D50X60X45H	4	
3#	020310080	NUT M10	4	
4#	030210250	WASHER, LOCK M10	4	
5	0105091025	BOLT 10X25 HEX HEAD ASSY.....	4.....	REPLACES P/N 002411025
7#	417218560	ECCENTRIC ROTATOR	1	
8#	417350430	PULLEY	1	
9#	952400130	WASHER 9304	1	
10#	011708025	BOLT 8X25 HEX HEAD ASSY.....	1.....	REPLACES P/N 002210825
11#	951405240	KEY 7X7X19 R	1	
12#	040406208	BEARING 6208C4	2	
13#	417454390	PACKING (VIB.)	2	
15#	417339899	CASE COVER (R)	1	
16-1#	014208020	BOLT 8X20.....	4.....	REPLACES P/N 001220820
16-2#	030208200	WASHER, LOCK M8	4	
17#	0401450080	WASHER, FLAT M8.....	4.....	REPLACES P/N 031108160
18#	953405270	PLUG 1/4X14 13L	1	
19#	953405260	PACKING 1/4	1	
21#	417339909	CASE COVER (L)	1	
22#	060403020	OIL SEAL	1	
23#	096208010	SOCKET HEAD BOLT 8X15.....	4.....	REPLACES P/N 001520815
24#	417339910	COVER SEAL (VIB.)	1	

# ENGINE ASSY.

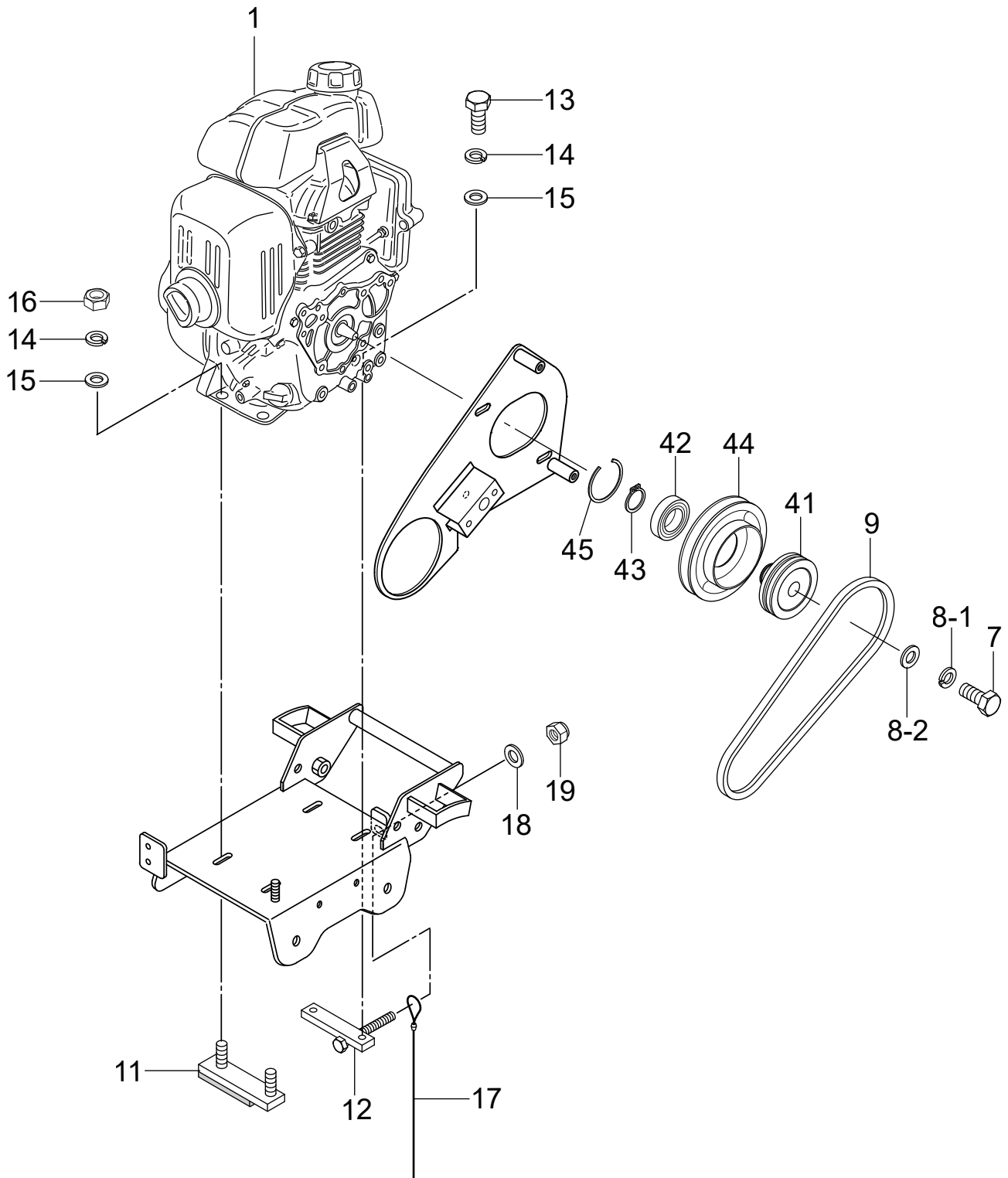

## ENGINE ASSY.

<u>NO.</u>	<u>PART NO.</u>	<u>PART NAME</u>	<u>QTY.</u>	<u>REMARKS</u>
1	912210033	ENGINE ASSY. GX100UTVMA	1	
7	011208025	BOLT 8X25.....	1.....	REPLACES P/N 001220825
8-1	030208200	WASHER, LOCK M8	1	
8-2	031108200	WASHER, FLAT M8	1	
9	070100282	V-BELT, RPF-3280	1	
11	417470980	PLATE, BOLT WITH RUBBER	1	
12	417471110	ENGINE NUT, REAR	1	
13	014208020	BOLT 8X20.....	2.....	REPLACES P/N 001220820
14	030208200	WASHER, LOCK M8	4	
15	0401450080	WASHER, FLAT M8.....	4.....	REPLACES P/N 031108160
16	020108060	NUT M8 .....	2.....	REPLACES P/N 020308060
17	959404350	EARTH WIRE	1	
18	0401450080	WASHER, FLAT M8.....	1.....	REPLACES P/N 031108160
19	022710809	NYLON NUT M8	1	
41	417355080	CLUTCH SHOE AND BOSS ASSY.	1	
42	042006006	BEARING.....	1.....	REPLACES P/N 044006006
43	080200300	STOP RING		
44	417470990	CLUTCH DRUM	1	
45	080600550	STOP RING	1	

# HONDA GX100UTVMA ENGINE — CYLINDER BARREL ASSY.

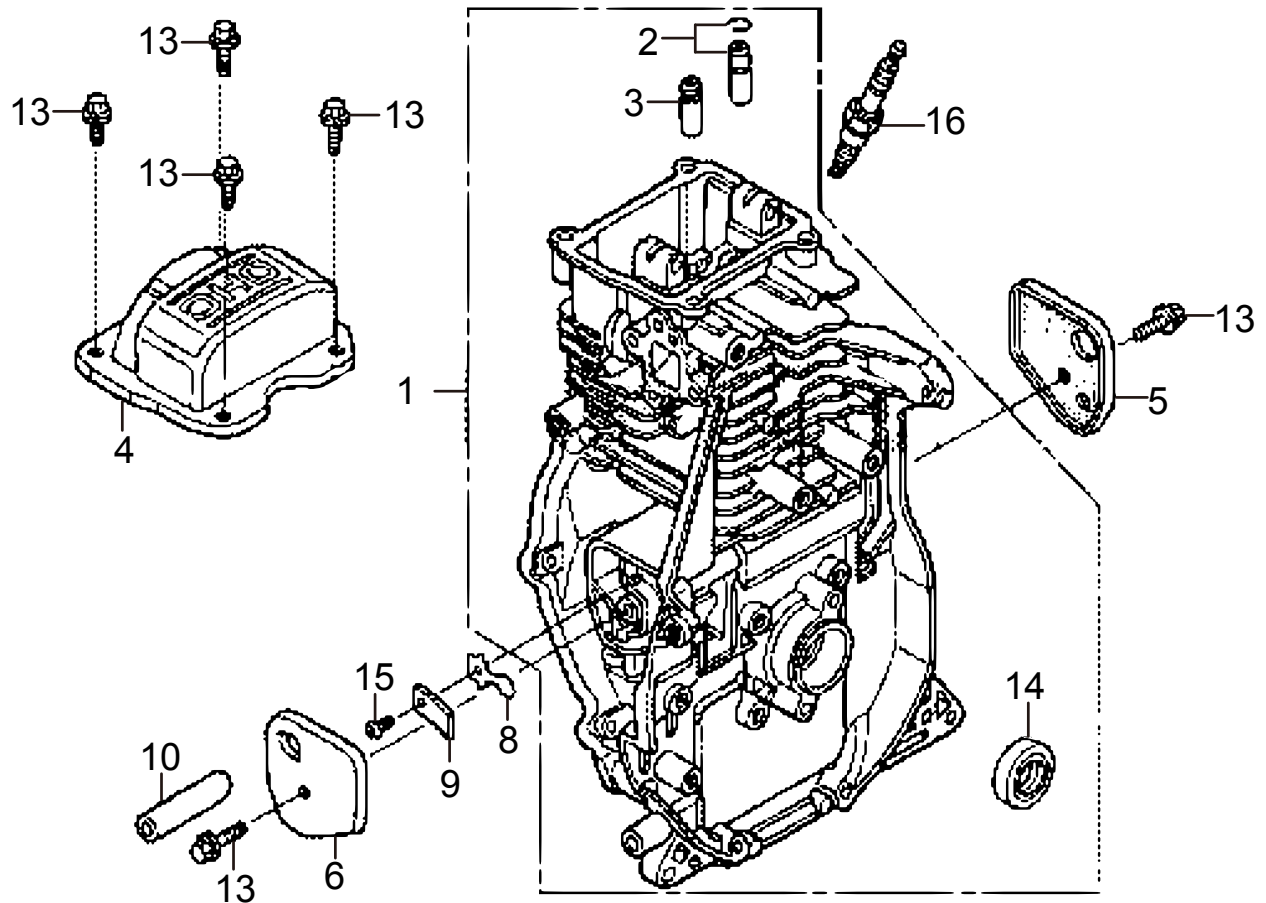

## HONDA GX100UTVMA ENGINE — CYLINDER BARREL ASSY.

---

<u>NO.</u>	<u>PART NO.</u>	<u>PART NAME</u>	<u>QTY.</u>	<u>REMARKS</u>
1	12000Z0D405	BARREL ASSY., CYLINDER .....	1.....	INCLUDES ITEMS W/\$
2\$	12201Z0D305	GUIDE ASSY., EXHAUST VALVE (OS)	1	
3\$	12204Z0D305	GUIDE, INLET VALVE (O.S.)	1	
4	12311Z0D000	COVER, HEAD	1	
5	12355Z0D000	COVER COMPLETE A, BREATHER	1	
6	12365Z0D000	COVER COMPLETE B, BREATHER	1	
8	15571ZM7003	VALVE, OIL OUTLET	1	
9	15572ZM7000	PLATE, STOPPER	1	
10	15721Z0D000	TUBE, BREATHER	1	
13	90014952000	BOLT, FLANGE 6X14	6	
14\$	91202KJ9003	OIL SEAL 20X32X6	1	
15	93500030050A	SCREW, PAN 3X5	1	
16	9805655777	SPARK PLUG	1	

# HONDA GX100UTVMA ENGINE — CRANKCASE COVER ASSY.

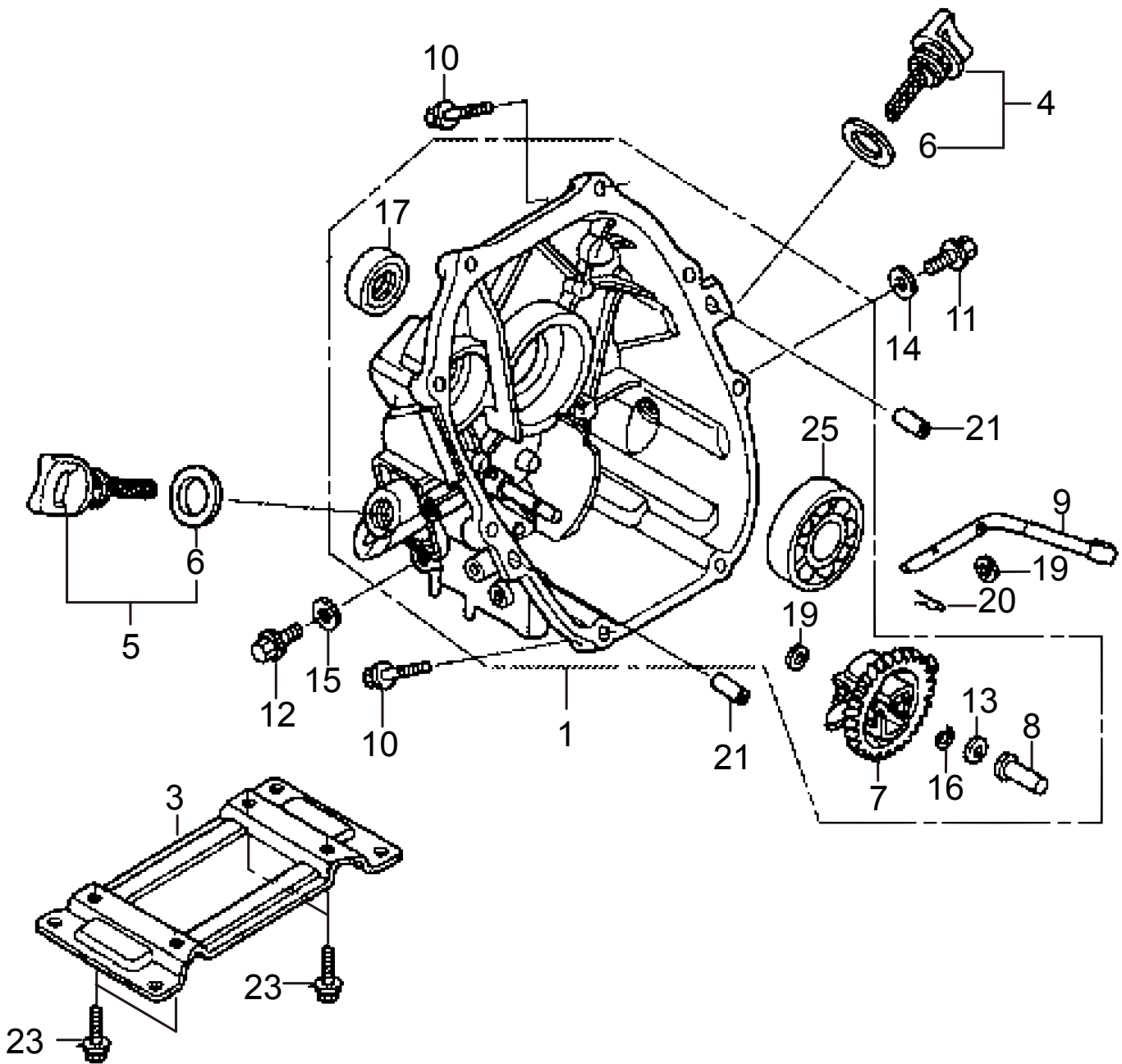



## HONDA GX100UTVMA ENGINE — CRANKCASE COVER ASSY.

<u>NO.</u>	<u>PART NO.</u>	<u>PART NAME</u>	<u>QTY.</u>	<u>REMARKS</u>
1	11300Z0D405	COVER ASSY., CRANK CASE.....	1.....	INCLUDES ITEMS W/#
3	12351Z0DT00	CRADLE, ENGINE	1	
4	15600ZDF000	CAP ASSY., OIL FILLER .....	1.....	INCLUDES ITEMS W/\$
5	15600ZDF000	CAP ASSY., OIL FILLER .....	1.....	INCLUDES ITEMS W/@
6\$@	15625Z0T800	PACKING, OIL FILLER CAP	2	
7#	16510ZL8000	GOVERNOR ASSY.	1	
8#	16531ZE1000	SLIDER, GOVERNOR	1	
9	16541Z0D000	SHAFT, GOVERNOR ARM	1	
10	957010602500	FLANGE BOLT 6X25 .....	8.....	REPLACES P/N 90121952000
11	90131ZE1000	BOLT, DRAIN PLUG	1	
12	90131ZE1000	BOLT, DRAIN PLUG	1	
13#	90451ZE1000	THRUST WASHER 6MM	1	
14	90601ZE1000	WASHER, DRAIN PLUG	1	
15	90601ZE1000	WASHER, DRAIN PLUG	1	
16#	90602ZE1000	CLIP, GOVERNOR HOLDER	1	
17#	91202KJ9003	OIL SEAL 20X32X6	1	
19	58176	WASHER, FLAT 6MM.....	2.....	REPLACES P/N 9410106800
20	9425108000	LOCK PIN 8MM	1	
21	9430108200	KNOCK PIN 8X20	2	
23	957010801800	FLANGE, BOLT 8X18	4	
25#	961006204000	BEARING, RADIAL BALL	1	

# HONDA GX100UTVMA ENGINE — CRANKSHAFT ASSY.

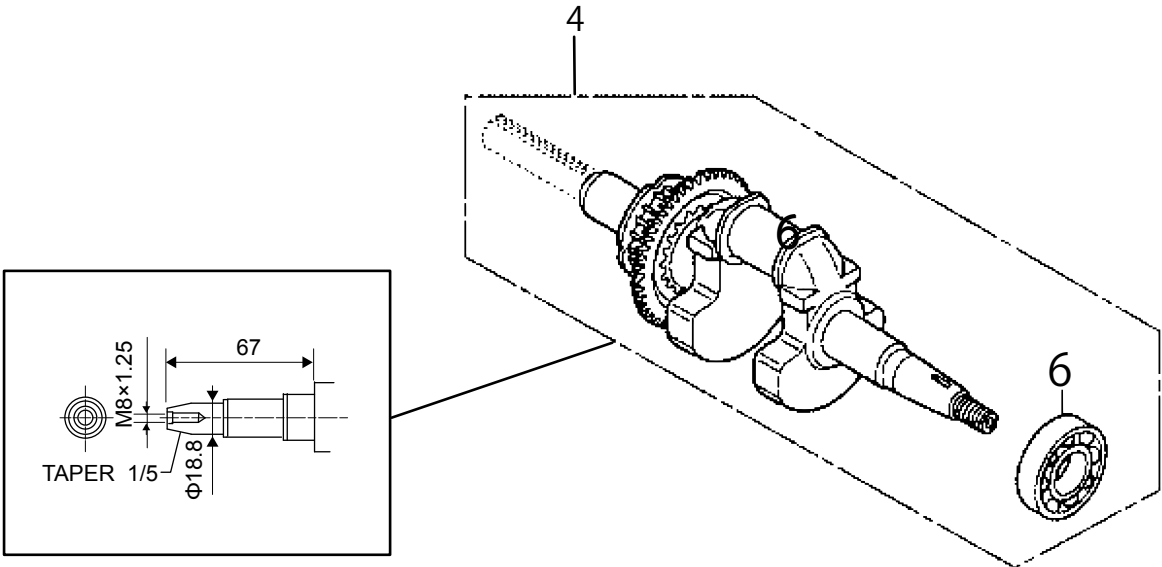

## HONDA GX100UTVMA ENGINE — CRANKSHAFT ASSY.

---

<u>NO.</u>	<u>PART NO.</u>	<u>PART NAME</u>	<u>QTY.</u>	<u>REMARKS</u>
4	13310Z0DV70	CRANKSHAFT COMPLETE.....	1.....	INCLUDES ITEM W/\$
6\$	91001Z0DV01	BEARING, RADIAL BALL	1	

# HONDA GX100UTVMA ENGINE — PIST. AND CONN. ROD ASSY.

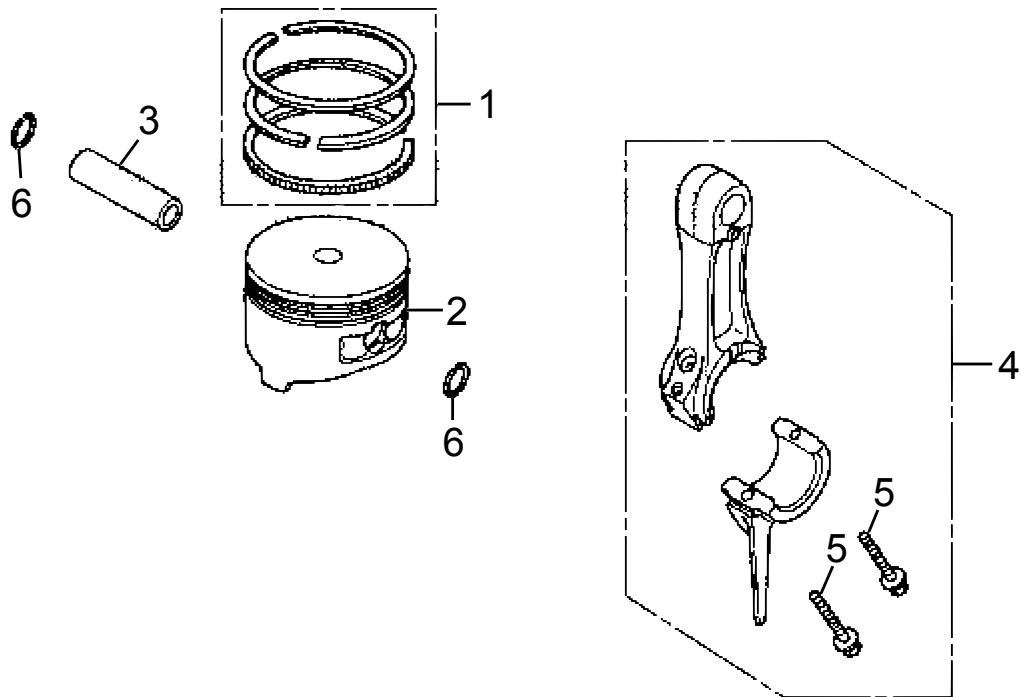

## **HONDA GX100UTVMA ENGINE — PIST. AND CONN. ROD ASSY.**

---

<u>NO.</u>	<u>PART NO.</u>	<u>PART NAME</u>	<u>QTY.</u>	<u>REMARKS</u>
1	13010Z0D003	RING SET, PISTON	1	
2	13101ZDD000	PISTON	1	
3	13111ZE0000	PISTON PIN	1	
4	13200Z0D000	CONNECTING ROD ASSY.....	1.....	INCLUDES ITEM W/#
4	13200Z0D305	CONNECTING ROD ASSY (UNDER) .....	1.....	INCLUDES ITEM W/\$
5#\$	90001ZM7000	CONNECTING ROD BOLT	2	
6	90551ZE0000	CLIP, PISTON PIN 13MM	2	

# HONDA GX100UTVMA ENGINE — CAMSHAFT PULLEY ASSY.

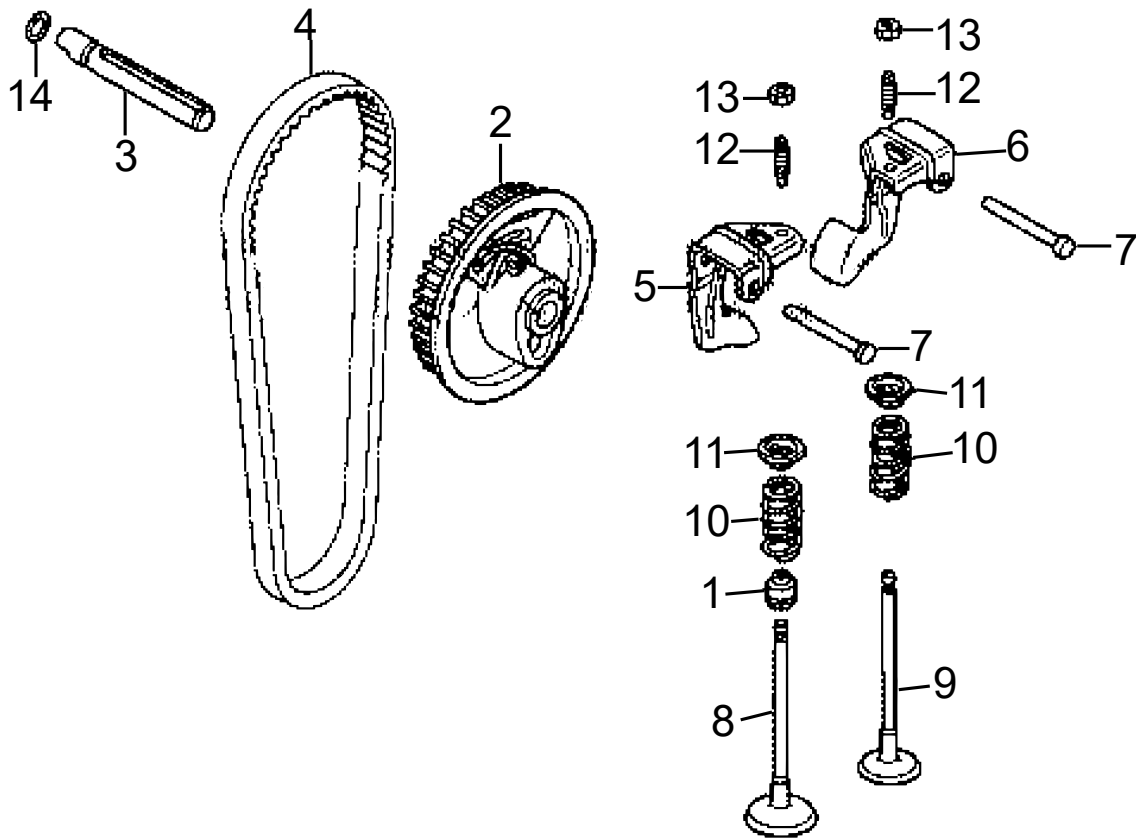

## HONDA GX100UTVMA ENGINE — CAMSHAFT PULLEY ASSY.

---

<u>NO.</u>	<u>PART NO.</u>	<u>PART NAME</u>	<u>QTY.</u>	<u>REMARKS</u>
1	12209KT7013	SEAL, VALVE STEM	1	
2	14320ZDD000	PULLEY COMP., CAMSHAFT/RTE	1	
3	14324Z0D000	SHAFT, CAM PULLEY	1	
4	14400Z0D003	TIMING BELT	1	
5	14431ZDD000	ROCKER ARM, INTAKE VALVE	1	
6	14441ZDD000	ROCKER ARM, EXHAUST VALVE	1	
7	14461ZL8000	SHAFT, ROCKER ARM	2	
8	14711Z0D000	INLET VALVE	1	
9	14721Z0D000	EXHAUST VALVE	1	
10	14751Z0D000	SPRING, VALVE	2	
11	14771ZM3010	RETAINER, VALVE SPRING	2	
12	90012333000	SCREW, TAPPET ADJUSTING	2	
13	90206001000	NUT, TAPPET ADJUSTING	2	
14	91301ZM0V31	O-RING 6.8X1.9	1	

# HONDA GX100UTVMA ENGINE — RECOIL STARTER ASSY.

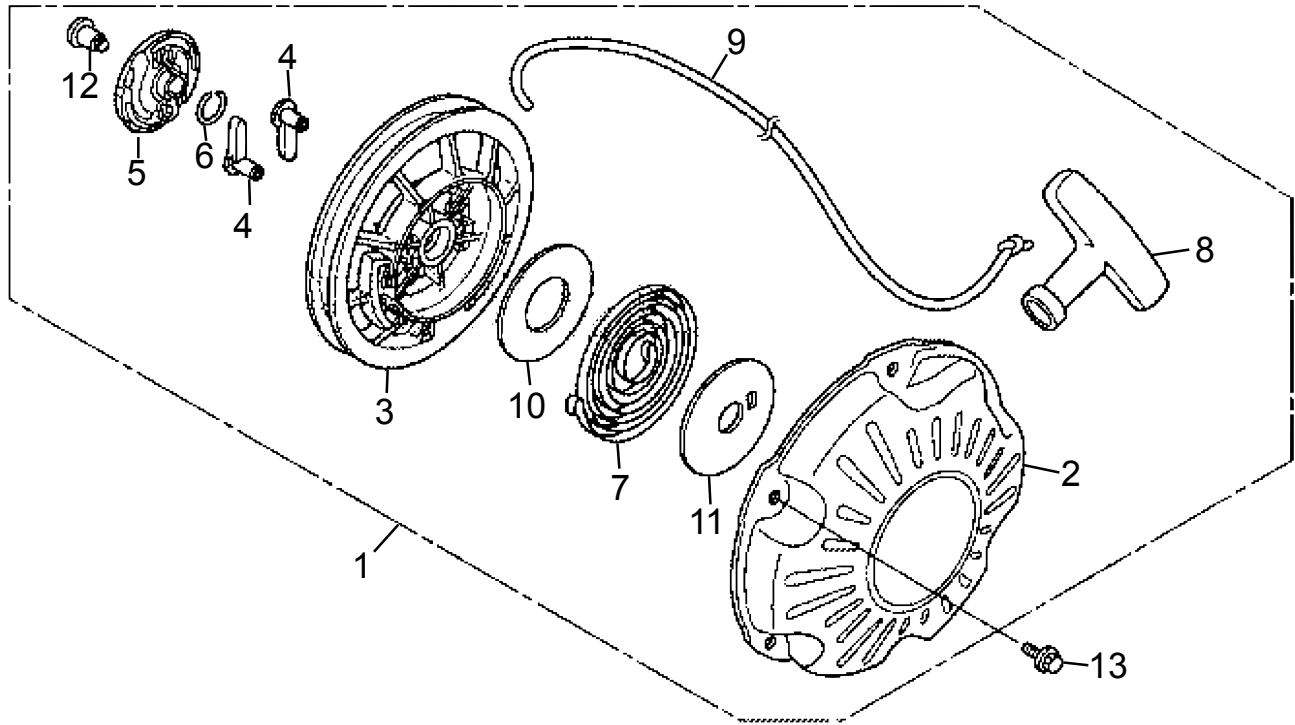



## HONDA GX100UTVMA ENGINE — RECOIL STARTER ASSY.

---

<u>NO.</u>	<u>PART NO.</u>	<u>PART NAME</u>	<u>QTY.</u>	<u>REMARKS</u>
1	28400Z0DV04ZA	RECOIL STARTER ASSY. ....	1.....	INCLUDES ITEMS W/\$
2\$	28410Z0DV02ZA	CASE COMPLETE/RECOIL	1	
3\$	28421ZDD003	REEL, RECOIL STARTER	1	
4\$	28422ZG0W02	RATCHET, STARTER	2	
5\$	28433ZG0W02	GUIDE, RATCHET	1	
6\$	28441ZW9003	SPRING, FRICTION .....	1.....	REPLACES P/N 28441ZW6003
7\$	28442ZH8003	SPRING, RECOIL STARTER	1	
8\$	28461ZDD003	KNOB, RECOIL STARTER	1	
9\$	28462Z0DV03	ROPE, RECOIL STARTER	1	
10\$	28467Z0DV02	PLATE, SIDE	1	
11\$	28468Z0DV02	PLATE, SLIDE	1	
12\$	90003ZH8003	SET SCREW	1	
13	957010600800	FLANGE BOLT 6X8	3	

# HONDA GX100UTVMA ENGINE — FAN COVER ASSY.

---

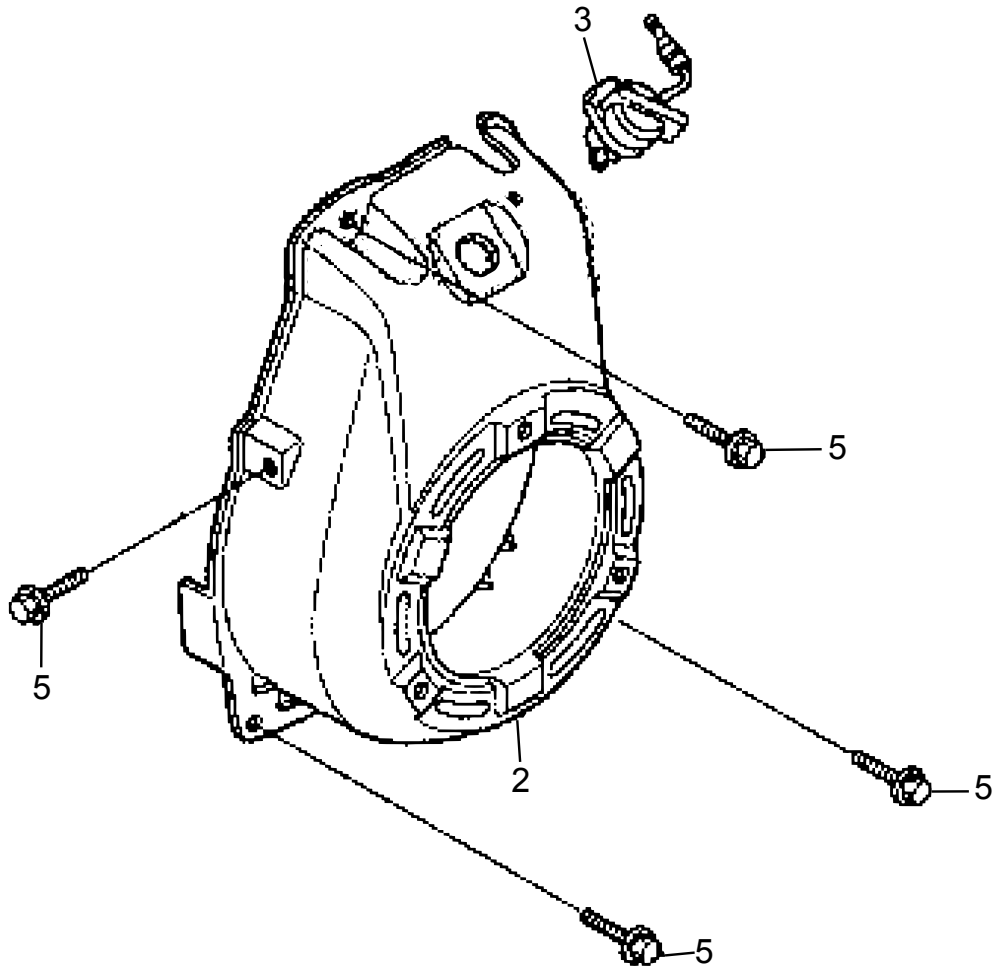

## HONDA GX100UTVMA ENGINE — FAN COVER ASSY.

---

<u>NO.</u>	<u>PART NO.</u>	<u>PART NAME</u>	<u>QTY.</u>	<u>REMARKS</u>
2	19610Z0DV00ZB	FAN COVER COMPLETE, BLACK	1	
3	35120Z0DV81	SWITCH ASSY., ENGINE STOP	1	
5	90014952000	BOLT, FLANGE 6X14	4	

# HONDA GX100UTVMA ENGINE — CARBURETOR ASSY.

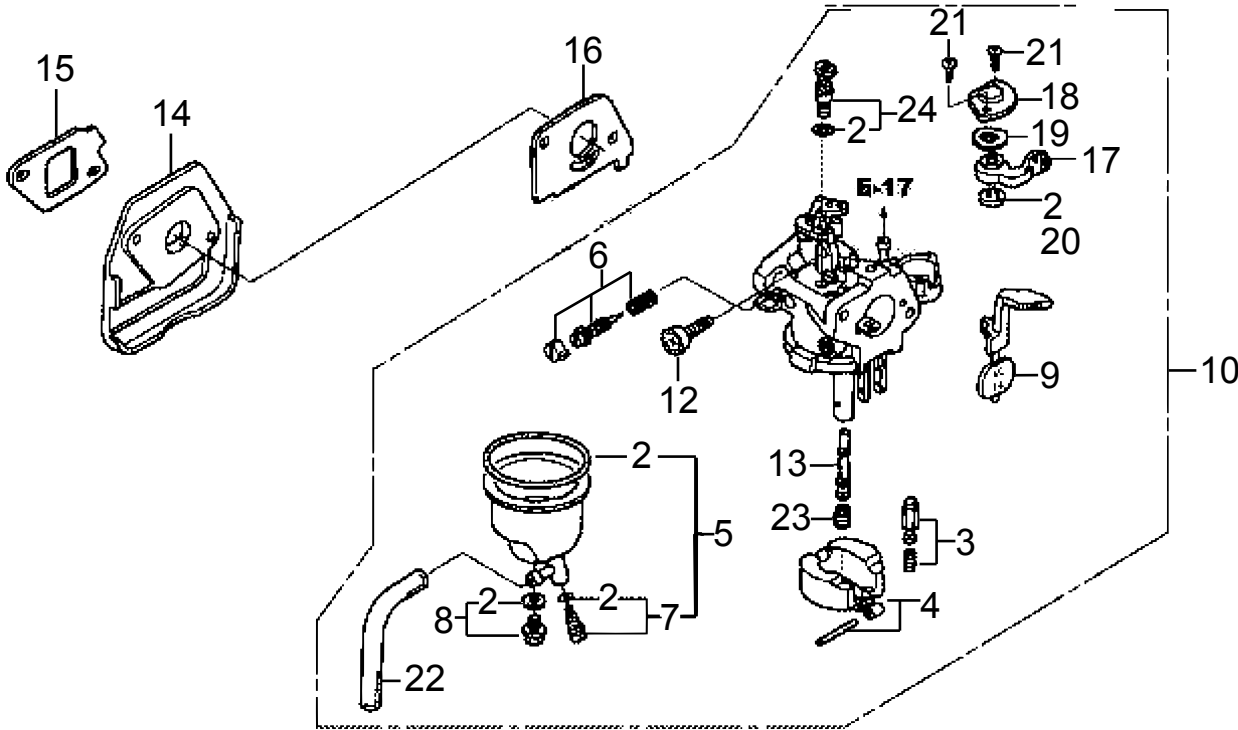

**NOTICE**  
Gasket set, item 2 included with items 5, 7, 8, 20 and 24.

## HONDA GX100UTVMA ENGINE — CARBURETOR ASSY.

<b>NO.</b>	<b>PART NO.</b>	<b>PART NAME</b>	<b>QTY.</b>	<b>REMARKS</b>
2\$#	16010ZM7003	GASKET SET	1	
3\$	16011ZE0005	FLOAT VALVE SET	1	
4\$	16013ZG0811	FLOAT SET	1	
5\$	16015ZM7003	FLOAT CHAMBER SET .....	1.....	INCLUDES ITEMS W/#
6\$	16016ZH7W01	SCREW SET, PILOT	1	
7\$	16024ZB9005	DRAIN SCREW SET .....	1.....	INCLUDES ITEMS W/#
8\$	16028ZG0811	SCREW SET .....	1.....	INCLUDES ITEMS W/#
9\$	16044Z4E003	CHOKE SET	1	
10	16100Z4E033	CARBURETOR ASSY.....	1.....	INCLUDES ITEMS W/\$
12\$	16124ZE0005	SCREW, THROTTLE STOP	1	
13\$	16166Z4E003	MAIN NOZZLE	1	
14	16211Z0D010	INSULATOR, CARBURETOR	1	
15	16212Z0D000	PACKING, INSULATOR	1	
16	16221ZG0801	PACKING, CARBURETOR	1	
17\$	16953Z0D003	LEVER, COCK	1	
18\$	16954ZE1812	PLATE, LEVER SETTING	1	
19\$	16956ZE1811	SPRING, COCK LEVER	1	
20\$	16957ZE1812	PACKING, FUEL COCK .....	1.....	INCLUDES ITEMS W/#
21\$	93500030060H	SCREW 3X6	2	
22\$	950030500160M	TUBE, VINYL 3.5X6.5X1M	1	
23\$	99101ZG0062	JET, MAIN	1	
24\$	99204ZE2040	PILOT JET SET #35 .....	1.....	INCLUDES ITEMS W/#

# HONDA GX100UTVMA ENGINE — AIR CLEANER ASSY.

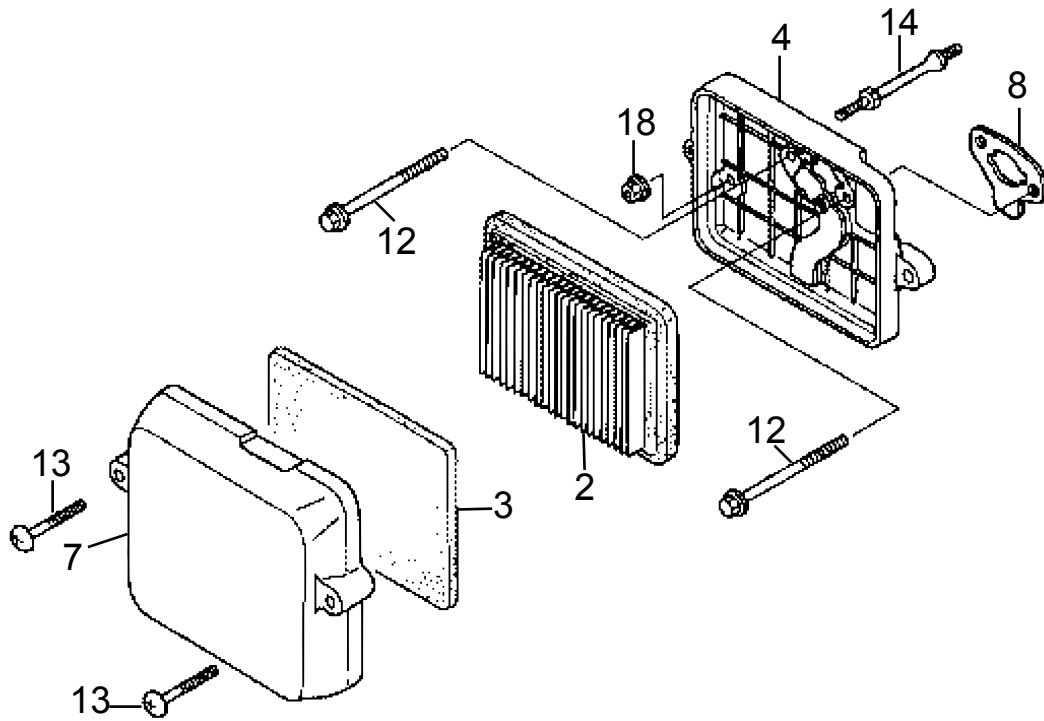

## HONDA GX100UTVMA ENGINE — AIR CLEANER ASSY.

---

<u>NO.</u>	<u>PART NO.</u>	<u>PART NAME</u>	<u>QTY.</u>	<u>REMARKS</u>
2	17211ZL8023	AIR CLEANER, ELEMENT, PAPER	1	
3	17218Z0D000	AIR CLEANER, ELEMENT, FOAM	1	
4	17220Z0DV22	CASE COMPLETE, AIR CLEANER	1	
7	17231Z0DV62	COVER, AIR CLEANER	1	
8	17274ZT3000	PACKING, AIR CLEANER	1	
12	90004Z0D000	BOLT, FLANGE 5X77	2	
13	90011Z0D000	BOLT, AIR CLEANER COVER	2	
14	90041Z0DV20	STUD BOLT	1	
18	9405006000	FLANGE NUT 6MM	1	

# HONDA GX100UTVMA ENGINE — MUFFLER ASSY.

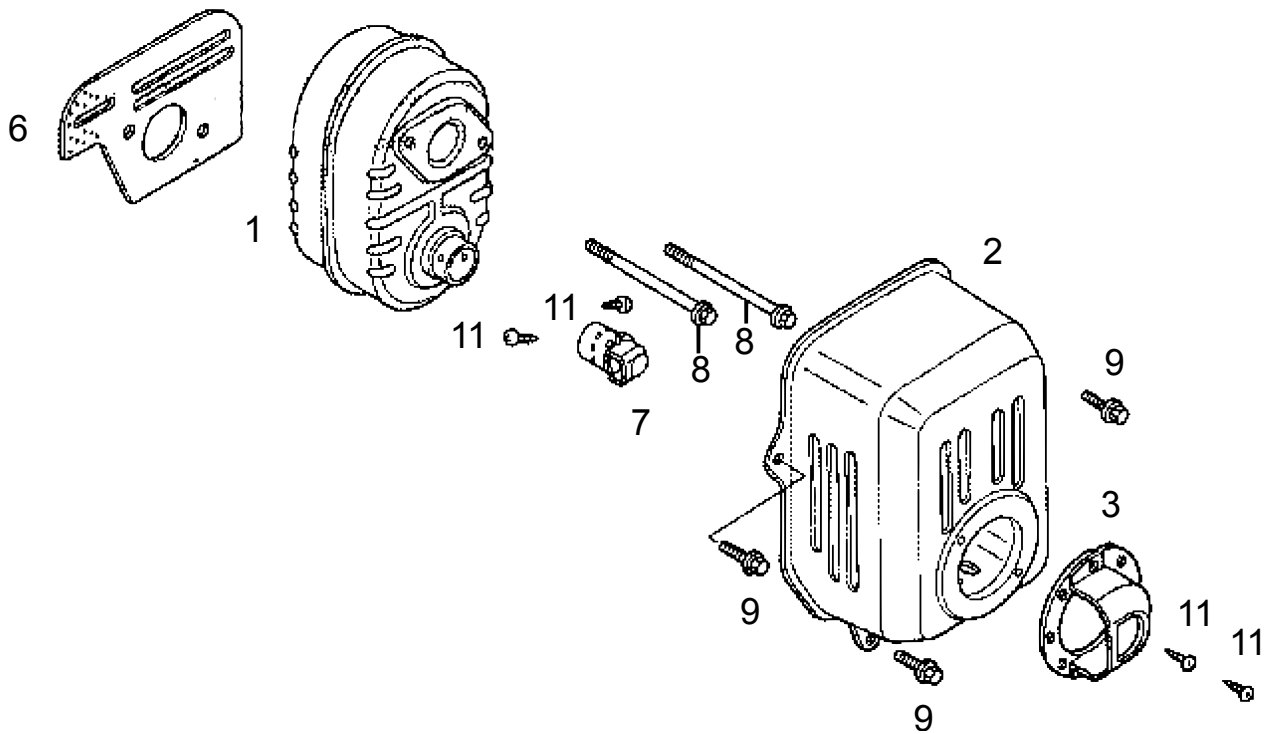



## HONDA GX100UTVMA ENGINE — MUFFLER ASSY.

---

<u>NO.</u>	<u>PART NO.</u>	<u>PART NAME</u>	<u>QTY.</u>	<u>REMARKS</u>
1	18310ZM0010	MUFFLER COMPLETE	1	
2	18320ZOM781	MUFFLER PROTECTOR	1	
3	18348ZL8000	CAP, MUFFLER	1	
6	18381Z0D000	GASKET, MUFFLER	1	
7	18430ZL8000	DEFLECTOR COMP., MUFFLER	1	
8	90004ZL8000	BOLT, FLANGE 6X79	2	
9	90014952000	BOLT, FLANGE 6X14	3	
11	90055ZE1000	TAPPING SCREW 4X6	4	

# HONDA GX100UTVMA ENGINE — FUEL TANK ASSY.

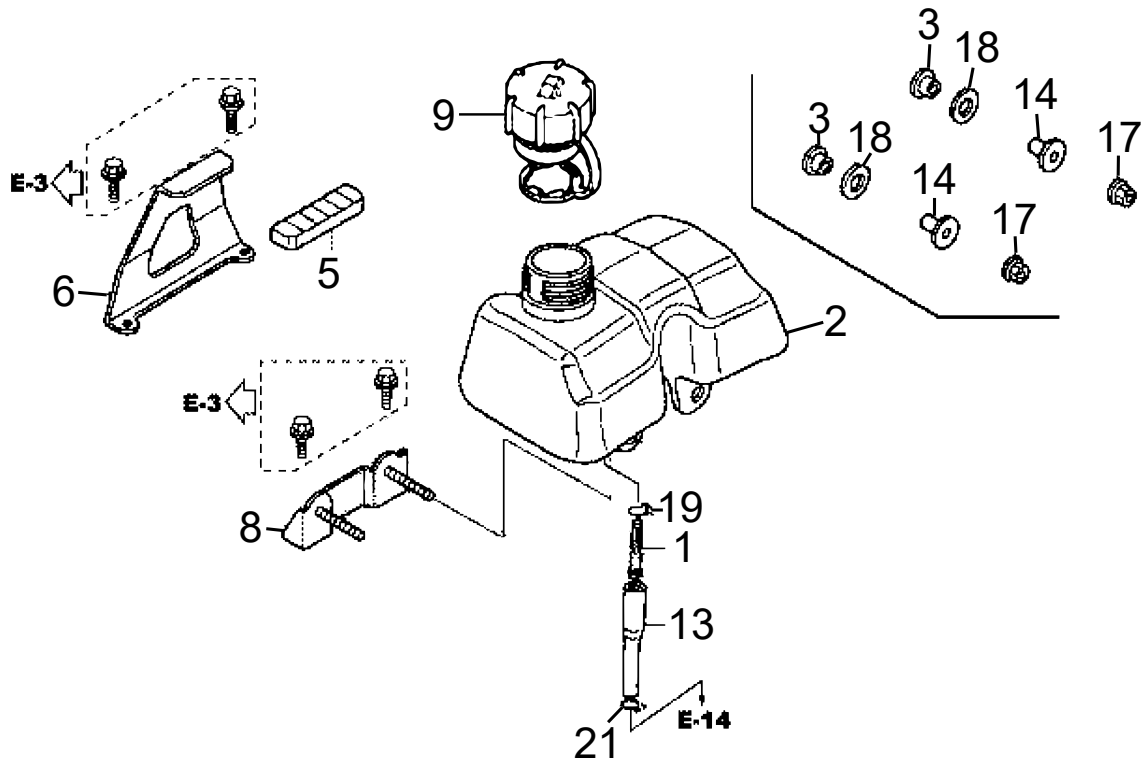

## HONDA GX100UTVMA ENGINE — FUEL TANK ASSY.

---

<u>NO.</u>	<u>PART NO.</u>	<u>PART NAME</u>	<u>QTY.</u>	<u>REMARKS</u>
1	16952ZE6000	STRAINER, FUEL	1	
2	17511Z4C810	TANK, FUEL	1	
3	17532Z0DT00	RUBBER A, TANK MOUNTING	2	
5	17533Z0DT00	RUBBER B, TANK MOUNTING	1	
6	17561Z0D000	STAY A, FUEL TANK	1	
8	17566Z0DT02	STAY B, FUEL TANK	1	
9	17620Z0J800	FUEL TANK CAP COMPLETE	1	
13	17701Z4E023	TUBE, FUEL	1	
14	19052MB4880	COLLAR, CANISTER MOUNTING	2	
17	90343ZE6000	NUT, SELF-LOCK 6MM	2	
18	90510KY1000	WASHER, FLAT 15MM	2	
19	950024105008	CLIP, TUBE	1	
21	950024080008	CLIP, TUBE	1	

# HONDA GX100UTVMA ENG. — FLYWHEEL/IGN. COIL ASSY.

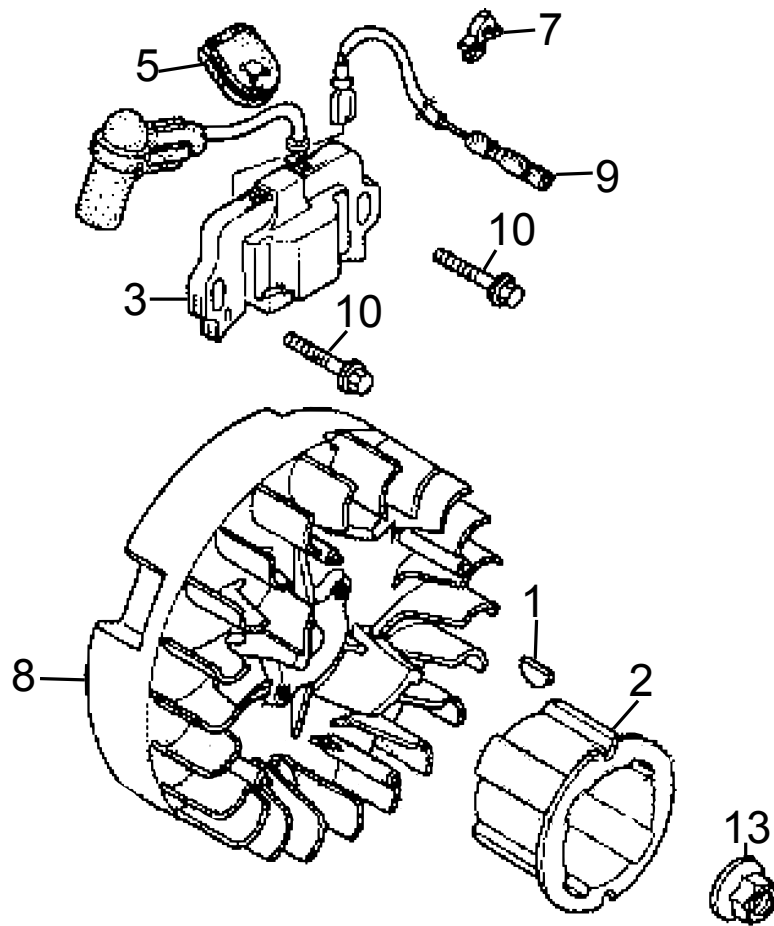

## **HONDA GX100UTVMA ENG. — FLYWHEEL/IGN. COIL ASSY.**

---

<u>NO.</u>	<u>PART NO.</u>	<u>PART NAME</u>	<u>QTY.</u>	<u>REMARKS</u>
1	13331ZM7000	WOODRUFF KEY 25X18	1	
2	28451Z0DV03	STARTER PULLEY	1	
3	30500Z0D023	IGNITION COIL ASSY.	1	
5	30564ZA5000	GROMMET, CORD	1	
7	30701883000	CLIP, HIGH TENSION CORD	1	
8	31110Z0D003	FLYWHEEL COMPLETE	1	
9	32195Z0D000	CORD, STOP SWITCH	1	
10	90022888010	FLANGE BOLT 6X20	2	
13	9405012000	FLANGE NUT M12	1	

# HONDA GX100UTVMA ENGINE — CONTROL ASSY.

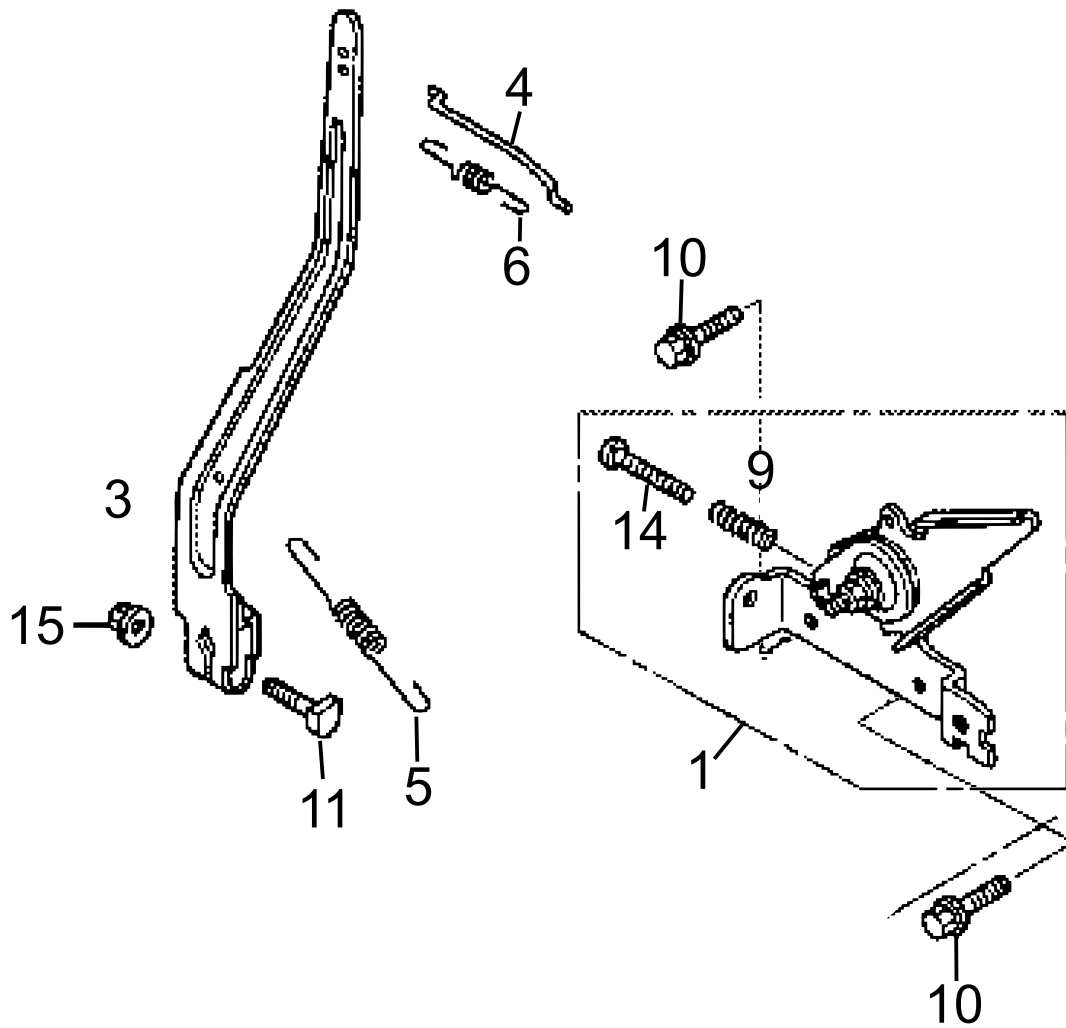

## HONDA GX100UTVMA ENGINE — CONTROL ASSY.

---

<u>NO.</u>	<u>PART NO.</u>	<u>PART NAME</u>	<u>QTY.</u>	<u>REMARKS</u>
1	16500Z0DT00	CONTROL ASSY.....	1.....	INCLUDES ITEMS W/\$
3	16551Z0D010	GOVERNOR ARM	1	
4	16555Z0D000	GOVERNOR ROD	1	
5	16561Z0D000	GOVERNOR SPRING	1	
6	16562Z0D000	SPRING, THROTTLE	1	
9\$	16584883300	ADJUSTING SPRING	1	
10	90014952000	BOLT, FLANGE 6X14	2	
11	90015Z5T000	BOLT, GOVERNOR ARM	1	
14\$	93500050250A	SCREW, PAN HD 5X25	1	
15	9405006000	FLANGE NUT 6MM	1	

# PARTS MANUAL

## HERE'S HOW TO GET HELP

PLEASE HAVE THE MODEL AND SERIAL  
NUMBER ON-HAND WHEN CALLING

### UNITED STATES

#### *Multiquip Inc.*

(310) 537- 3700  
6141 Katella Avenue Suite 200  
Cypress, CA 90630  
E-MAIL: [mq@multiquip.com](mailto:mq@multiquip.com)  
WEBSITE: [www.multiquip.com](http://www.multiquip.com)

### CANADA

#### *Multiquip*

(450) 625-2244  
4110 Industriel Boul.  
Laval, Quebec, Canada H7L 6V3  
E-MAIL: [infocanada@multiquip.com](mailto:infocanada@multiquip.com)

### UNITED KINGDOM

#### *Multiquip (UK) Limited Head Office*

0161 339 2223  
Unit 2, Northpoint Industrial Estate,  
Globe Lane,  
Dukinfield, Cheshire SK16 4UJ  
E-MAIL: [sales@multiquip.co.uk](mailto:sales@multiquip.co.uk)

© COPYRIGHT 2020, MULTIQUIP INC.

Multiquip Inc, the MQ logo are registered trademarks of Multiquip Inc. and may not be used, reproduced, or altered without written permission. All other trademarks are the property of their respective owners and used with permission.

This manual MUST accompany the equipment at all times. This manual is considered a permanent part of the equipment and should remain with the unit if resold.

The information and specifications included in this publication were in effect at the time of approval for printing. Illustrations, descriptions, references and technical data contained in this manual are for guidance only and may not be considered as binding. Multiquip Inc. reserves the right to discontinue or change specifications, design or the information published in this publication at any time without notice and without incurring any obligations.

Your Local Dealer is:

