

AVAILABLE FOR RENT OR SALE

SKYJACK[™]

COMPACT SERIES

SJIII 3219



www.atsequipment.com

DC ELECTRIC 19' SCISSOR LIFT



Compact Series

DC ELECTRIC Scissor Lifts

The Compact Series DC Electric Scissor Lifts offer Skyjack's easy to service, low maintenance design in a compact and versatile package. Equipped with variable speed front wheel hydraulic drive, and 90° steering, this model is capable of maneuvering in the smallest spaces. Featuring a 3' roll out extension deck, this Compact series model offers work heights of up to 25' and 25% gradeability. The platform on the SJIII 3219 boasts an industry leading capacity of 550lbs. The SJIII 3219 features durable steel swing-out component trays, providing unrestricted access for easy maintenance and service. Consistent with Skyjack's robust and reliable design features, the Compact series DC Electric Scissor lifts utilize Skyjack's standard color coded and numbered wiring system with analog based controls

ATS EQUIPMENT INC. Construction Equipment & Supplies Rentals • Sales • Service

BOSTON, MA
(617) 825-3600

AUBURN, MA
(508) 832-8500

REHOBOTH, MA
(508) 379-6200

CANDIA, NH
(603) 483-2100

COMPACT SERIES - DC ELECTRIC SCISSOR LIFTS

SPECIFICATIONS	SJIII 3219
A) Work Height	25'
B) Raised Platform Height	19"
C) Lowered Platform Height	39"
D) Overall Width	32"
E) Overall Length	70"
F) Stowed Height (Rails Up)	78.5"
G) Stowed Height (Rails Down)	OPT 64.5"
H) Platform width (Inside Dimension)	26"
I) Platform Length (Inside Dimension)	64"
Extension Deck (Roll Out)	3'
Ground Clearance (Stowed)	2.375"
Ground Clearance (Raised)	0.7"
Wheelbase	55"
Weight	2,580lbs
Gradeability	25%
Turning Radius (Inside)	0"
Turning Radius (Outside)	66"
Lift Time (With Rated Load)	25 sec
Drive Speed (Stowed)	2 mph
Drive Speed (Raised)	0.7 mph
Maximum Drive Height	Full Height
Capacity (Overall)	550 lbs
Maximum # of Persons	2



STANDARD FEATURES

- Drivable at full height
- Variable speed, front two wheel hydraulic drive
- 90° steering (zero inside turning radius)
- Dual holding brakes
- Proportional controls for drive & lift functions
- 3' roll out extension deck
- 24V DC power source
- Low voltage battery protection
- Analog control system
- Color coded and numbered wiring system
- 25% gradeability
- Solid rubber, non-marking tires
- Pothole protection system
- 110V AC outlet on platform with GFI
- Tilt alarm with drive & lift cut-out
- All motion audible alarm
- Operator horn
- Lanyard attachment points
- Forklift pockets and tie down/lift lugs

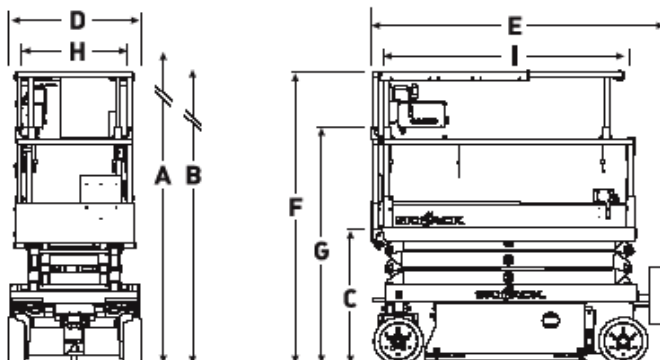

ATS EQUIPMENT INC. Construction Equipment & Supplies Rentals • Sales • Service

BOSTON, MA
(617) 825-3600

AUBURN, MA
(508) 832-8500

REHOBOTH, MA
(508) 379-6200

CANDIA, NH
(603) 483-2100