

SKYJACK™

AVAILABLE FOR RENT OR SALE

COMPACT SERIES SJ 6826 RT



www.atsequipment.com

ROUGH TERRAIN 26' SCISSOR LIFT



COMPACT SERIES

Rough Terrain Scissor Lifts

Skyjack's Compact Series Rough Terrain Scissor Lifts offer the same industry leading rugged, robust, and reliable scissor lifts that have made Skyjack famous.

The SJ 6826 RT comes equipped with an exclusive cross over symmetrical 4WD system for superior traction. Featuring up to 50% gradeability, this machine can operate on any job site terrain.

Standard features also include an easy to use 5' roll out extension deck, which can be secured in multiple positions for increased platform space and improved reach capabilities.

This compact model is drivable at full height with the roll out deck fully extended. A low stowed height is ideal for loading and unloading tools and materials.

Consistent with Skyjack's robust and reliable design features, the Compact Series Rough Terrain Scissor lifts utilize Skyjack's standard color coded numbered wiring system with analog based controls.

ATS EQUIPMENT INC. Construction Equipment & Supplies Rentals • Sales • Service

**BOSTON, MA
(617) 825-3600**

**AUBURN, MA
(508) 832-8500**

**CANDIA, NH
(603) 483-2100**

SJ 6826 RT

ATS EQUIPMENT INC.
www.atsequipment.com

COMPACT SERIES - ROUGH TERRAIN SCISSOR LIFTS

SPECIFICATIONS	SJIII 6826 RT
A) Work Height	32'
B) Raised Platform Height	26'
C) Lowered Platform Height	48.5"
D) Overall Width	68"
E) Overall Length	107"
F) Stowed Height (Rails Up)	93.5"
G) Stowed Height (Rails Down)	63.5"
H) Platform width (Inside Dimension)	56"
I) Platform Length (Inside Dimension)	96"
Extension Deck (Roll Out)	5'
Ground Clearance	8"
Wheelbase	80.5"
Weight	6,400 lbs
Gradeability	50%
Turning Radius (Inside)	60"
Turning Radius (Outside)	156"
Lift Time (With Rated Load)	36 sec
Drive Speed (Stowed)	3.8 mph
Drive Speed (Raised)	0.4 mph
Maximum Drive Height	Full Height
Capacity (Overall)	1250 lbs
Maximum # of Persons	4



STANDARD FEATURES

- Drivable at full height with roll out deck fully extended
- Crossover symmetrical 4WD
- Multiple wet disc spring applied hydraulic release brakes
- 5' roll out extension deck
- 31hp Kubota Dual fuel (gas/propane) engine
- 90° swing out engine tray
- Analog control system
- Color coded and numbered wiring system
- Up to 50% gradeability
- Foam-filled low profile grip lug tires
- 110V AC outlet on platform with GFI
- Tilt alarm with drive & lift cut-out
- All motion audible alarm
- Operator horn
- Hinged railing system
- Full height spring hinged gate at rear of unit
- Lanyard attachment points
- Forklift pockets and tie down/lift lugs

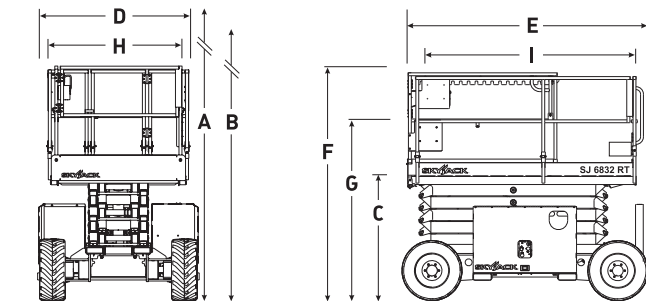

ATS EQUIPMENT INC. Construction Equipment & Supplies Rentals • Sales • Service

BOSTON, MA
(617) 825-3600

AUBURN, MA
(508) 832-8500

CANDIA, NH
(603) 483-2100