

AVAILABLE FOR RENT OR SALE

**SKYJACK**<sup>™</sup>

**A-SERIES**

**SJ 46AJ**



[www.atsequipment.com](http://www.atsequipment.com)

## ARTICULATING BOOM LIFT



### A-SERIES

## Articulating BOOM LIFTS

Skyjack's new A-SERIES Articulating Boom has been engineered utilizing many of Skyjack's robust and reliable design features. The 46AJ Model is featured with jib. It also boasts an industry leading, standard equipped, 360 degree continuous turret rotation. Zero tail swing compliments the unique turret design allowing for flexible operation in tight locations. Superior positive traction and terrainability is provided by the axle based 4WD used in many of Skyjack product designs, which accounts for a provel low maintenance, rugged and reliable drive train. The SJ 46AJ is equipped with a rear axle hydraulic differential lock/unlock switch allowing the operator to lock the rear differential when negotiating rough terrain. The unlocked position improves turning radius and reduces tire marks on hard surfaces.

Rounding out some of the other key features include; direction sensing drive and steer controls, true vertical rise with riser function which prevents drifting forward or backwards, analog based controls and Skyjack's standard color coded numbered wiring system.

**ATS EQUIPMENT INC. Construction Equipment & Supplies Rentals • Sales • Service**

**BOSTON, MA  
(617) 825-3600**

**AUBURN, MA  
(508) 832-8500**

**CANDIA, NH  
(603) 483-2100**

## A-SERIES - ARTICULATING BOOM LIFTS

DIMENSIONAL SPECIFICATIONS	SJ 46AJ
Platform Height	46' 5"
Horizontal Reach	25' 2"
Up and Over Height	25' 0"
Platform Size	30" x 72"
Stowed Width	88"
Tail Swing	ZERO
Stowed Height	82"
Stowed Length	21' 5"
Wheelbase	80"
Ground Clearance	16"
Rotation	360° Continuous
Platform Rotation	180°
Jib Length	5'
Jib Range	+70°/-75°

TECHNICAL SPECIFICATIONS	SJ 46AJ
Weight	14,730lbs
Gradeability	45%
Turning Radius (inside)	98"
Turning Radius (outside)	203"
Axle Oscillation	8"
Drive Speed (High Speed)	4.8 mph
Capacity	500 lbs
Maximum # of persons	2
Tire Type	Air Filled
Tire Size	315/55 D20
Diesel Engine (Deutz D2011 L03i)	48 HP
Dual Fuel Engine (GM 3.0L Vortech)	82 HP
Fuel Tank Capacity	17 gallon
Hydraulic Reservoir	24 gallon



### STANDARD FEATURES

- Axle based 4WD system
- Operator controlled locking rear differential and limited slip front differential
- Oscillating axle
- Drivable at full height
- 360° continuous turret rotation
- 45% Gradeability
- 82 HP GM Dual Fuel engine
- Swing out engine tray
- Swing up cowlings
- Modular platform railing system
- Spring hinged gate
- 110V AC outlet on platform with GFI
- Direction sensing drive and steer controls
- Proportional controls
- Relay based control system
- Color coded and numbered wiring
- Hourmeter
- Operator horn
- All motion alarm
- Tie down/Lifting lugs
- Wet disc SAHR brakes (rear axle)
- 315/55 D20 grip lug air-filled tires

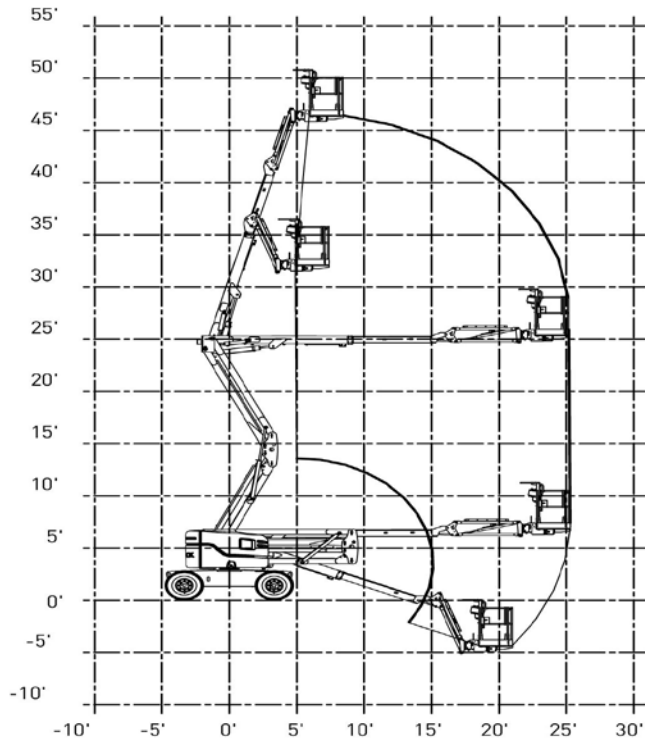

**ATS EQUIPMENT INC. Construction Equipment & Supplies Rentals • Sales • Service**

**BOSTON, MA**  
**(617) 825-3600**

**AUBURN, MA**  
**(508) 832-8500**

**CANDIA, NH**  
**(603) 483-2100**