

Genie®

SUPERLIFT CONTRACTOR®

SLC-18

AVAILABLE FOR RENT



www.atsequipment.com

MATERIAL LIFT

Ideal For Construction firms and all types of contractors, the Genie® Superlift Contractor® is well suited for industrial applications and HVAC installations. This unit can be easily operated by one person and can lift, lower and move loads up to 650 lbs to heights of up to 24 ft.



EASY TRANSPORT AND SETUP

Glide rails allow one person to easily hold or upload the unit and lift it in or out of a pickup truck. Rear transport wheel assembly also facilitates maneuvering on uneven surfaces. Quick setup requires no tools.



STOWED POSITION

The heavy duty patented telescoping mast system stows in a compact position. Legs fold up and attachments are removable for easy storage.

Designed Specifically for the construction industry, these heavy-duty units are extremely durable yet also lightweight and portable

ATS EQUIPMENT INC. Construction Equipment & Supplies Rentals • Sales • Service

**BOSTON, MA
(617) 825-3600**

**AUBURN, MA
(508) 832-8500**

**CANDIA, NH
(603) 483-2100**

MATERIAL LIFT SUPERLIFT CONTRACTOR®

SPECIFICATIONS

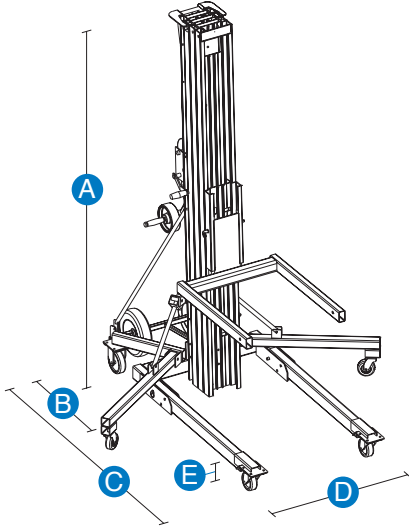

MEASUREMENTS SLC-18

Working height:	
standard forks - forks down	16 ft 9 in
standard forks - forks up	18 ft 6 in
adjustable forks - forks down	16 ft 9 in
adjustable forks - forks up	18 ft 6 in
boom**	17 ft 9 in

A	Height - stowed	7 ft 2 in
B	Length - stowed	2 ft 10 in
C	- operating	6 ft 1 in
D	Width - stowed*	2 ft 7.5 in
	- with stabilizers lowered	5 ft 6 in

PRODUCTIVITY

Load capacity:	
14 in (36 cm) load center	650 lbs
24 in (61 cm) load center	425 lbs
42 in (107 cm) load center	160 lbs

E Ground clearance	2 in
Load height minimum	6 in

POWER

Average cranks standard winch	8.5 cranks/ft
-------------------------------	---------------

WEIGHT

307 lbs

LOAD HANDLING ATTACHMENTS

Standard forks (l/w/d)***	28/23/2.5 in
Adjustable forks (l/w/d)***	27.5/12-30/2.5 in
Fork extensions detached (each) (l/w/d)***	30/2/3 in
Fork extensions attached (each) (l/w/d)***	25/2/3 in
Boom (l/w/d)***	18-42/1.5/6 in
Load platform (l/w/d)***	26.3/23/2.5 in

STANDARD FEATURES

- SLC™-18
- 18 ft 6 in (5.64 m) maximum lifting height
- Up to 650 lb (295 kg) lift capacity

PRODUCTIVITY

- Standard forks
- Heavy-duty design
- Strong, lightweight aluminum telescoping mast
- Single door access
- Quick set up requires no tools
- Interchangeable load handling attachments
- Non-marking 4 in (10 cm) front casters and 5 in (13 cm) rear casters with side brakes
- Rear transport wheel assembly
- Glide rails allow easy loading and unloading, on or off a vehicle, for transport
- Hold-down bar secures mast assembly during transport
- Captive stabilizer set (standard on SLC™-18, -24)

POWER

- One speed manual winch

OPTIONS & ACCESSORIES

PRODUCTIVITY

- Boom
- Adjustable forks
- Fork extensions
- Pipe cradle (available aftermarket only)
- Load platform
- Stabilizer set (option on SLC™-12)

POWER

- Two speed manual winch (available aftermarket only)



* Outside dimensions.

** Measured from ground to bottom of shackle.

*** Length/Width/Depth.