

# ASV

AVAILABLE FOR RENT AT

**ATS**  
EQUIPMENT INC.

[www.atsequipment.com](http://www.atsequipment.com)



## **RC-50** **Posi-Track™ Rubber Track** **Skid Steer Loader**

**ATS EQUIPMENT INC. Construction Equipment & Supplies Rentals • Sales • Service**

**BOSTON, MA**  
**(617) 825-3600**

**AUBURN, MA**  
**(508) 832-8500**

**CANDIA, NH**  
**(603) 483-2100**

## Posi-Track™ Rubber Track Skid Steer Loader

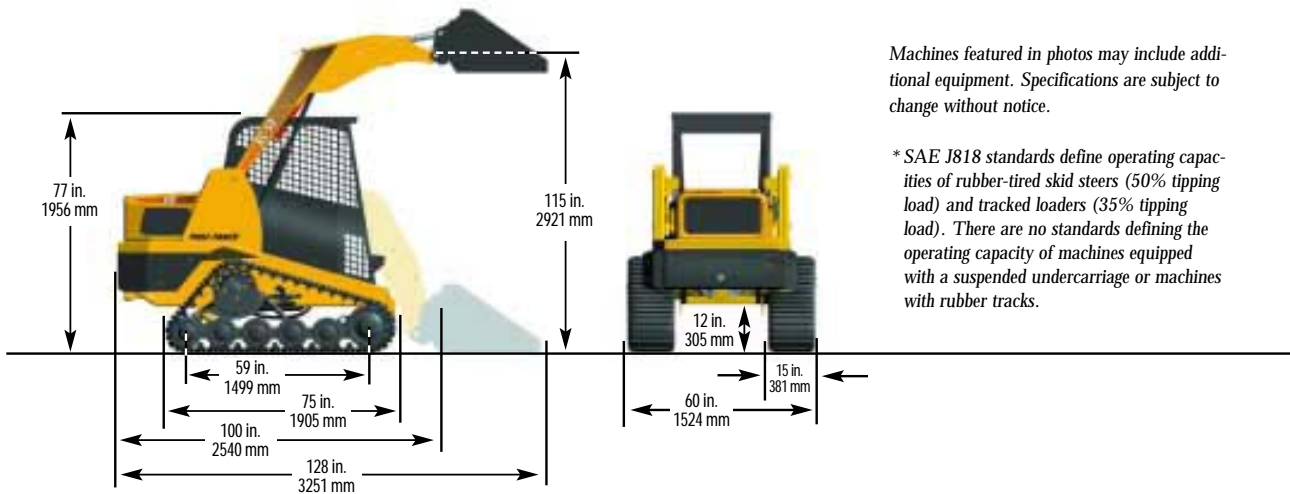

Machines featured in photos may include additional equipment. Specifications are subject to change without notice.

\*SAE J818 standards define operating capacities of rubber-tired skid steers (50% tipping load) and tracked loaders (35% tipping load). There are no standards defining the operating capacity of machines equipped with a suspended undercarriage or machines with rubber tracks.

### Machine Weight

Operating weight:	6,200 lb. / 2812 kg.
Shipping weight, w/out bucket:	5,500 lb. / 2495 kg.
Ground pressure:	
@ shipping weight	3.1 psi / 21.4 kPa
@ operating weight	3.5 psi / 24.1 kPa

### Track Specifications

Track width:	15 in. / 381 mm
Track length, on ground:	59 in. / 1499 mm
Ground contact area:	1,770 in. <sup>2</sup> / 1.14 m <sup>2</sup>

### Auxiliary Hydraulic Pump

Flow, maximum:	16.3 gpm / 61.7 lpm
Pressure:	3,000 psi / 20 670 kPa

### Engine

Type (Diesel):	Perkins 404C-22
Displacement:	134 in. <sup>3</sup> / 2.2 L
Gross power @ 2800 rpm:	50 hp / 37.3 kW
Torque, peak:	105 ft-lb / 143 Nm

### Operating Specifications

Tipping load:	3,800 lb. / 1724 kg
Operating capacity 50% tip load*:	1,900 lb. / 862 kg
Operating capacity 35% tip load*:	1,330 lb. / 603 kg
Travel speed, max.:	8 mph / 13 kmh

### Service Refill Capacities

Fuel tank:	15 gal. / 56.8 L
Hydraulic tank:	8 gal. / 30.3 L
Engine coolant:	2 gal. / 7.5 L
Engine oil, inc. filter:	2.8 gal. / 10.6 L

### Standard Features

Air cleaner, dual-stage	Loader arms
Alternator, 55-amp	Operator presence switch
Attachment control, elect.	Posi-Power Control (PPC)
Auxiliary hydraulics	Quick-attach, manual
Battery, 770 CCA	Quick-connect auxiliary hydraulic fittings
Brake, parking	ROPS/FOPS canopy
Bucket controls, pilot hyd.	Rubber track undercarriage
Bucket positioning, selectable	Screened engine compartment
Drive control, pilot hyd.	Throttle, hand & foot-operated
Electrical system, 12-volt	Tie-down loops, front/rear
Engine, diesel, Perkins 404C-22	Transmission, hydrostatic
Final drive, direct hydrostatic	Seat belt, two-inch wide
Fuse box, automotive type	Working lights, halogen:
Gauges:	- two front, fixed
- fuel level	- one rear, adjustable
- hour meter	Warning lights:
- slope indicator	- coolant temp
Heater, engine block	- engine oil pressure
Hitch receiver	- hot hydraulic oil
Ignition switch, key	- low battery
Interior dome light	Wiring - pre-installed for all accessory switches
Lap bar/arm rest	

### Options

Air conditioner/heater	Horn
Back-up alarm	Lift points, bolt-on
Beacon, rotating	Seat belt, three-inch wide
Brushguard	Side windows w/sliding glass
Cab enclosures	Sound insulation
Case-style controls	Track tensioner, grease
Front door	Window, rear, glass
Heater, cab	Wiper, front door